



supreme

PRODUCTS
Make Life Better!

Experts in solar Water Heaters Since 2004 (Mfd by : ISO 9001 : 2015 & 14001 : 2015 Certified Company)



APPROVED BY
20 YEARS GUARANTEE
MNRE. Govt. of India

Switch on the sun
Free hot water for life
Govt. Approved Company

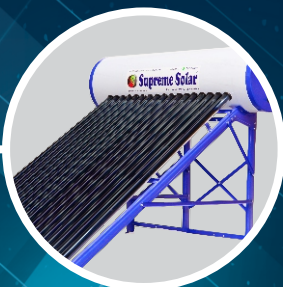
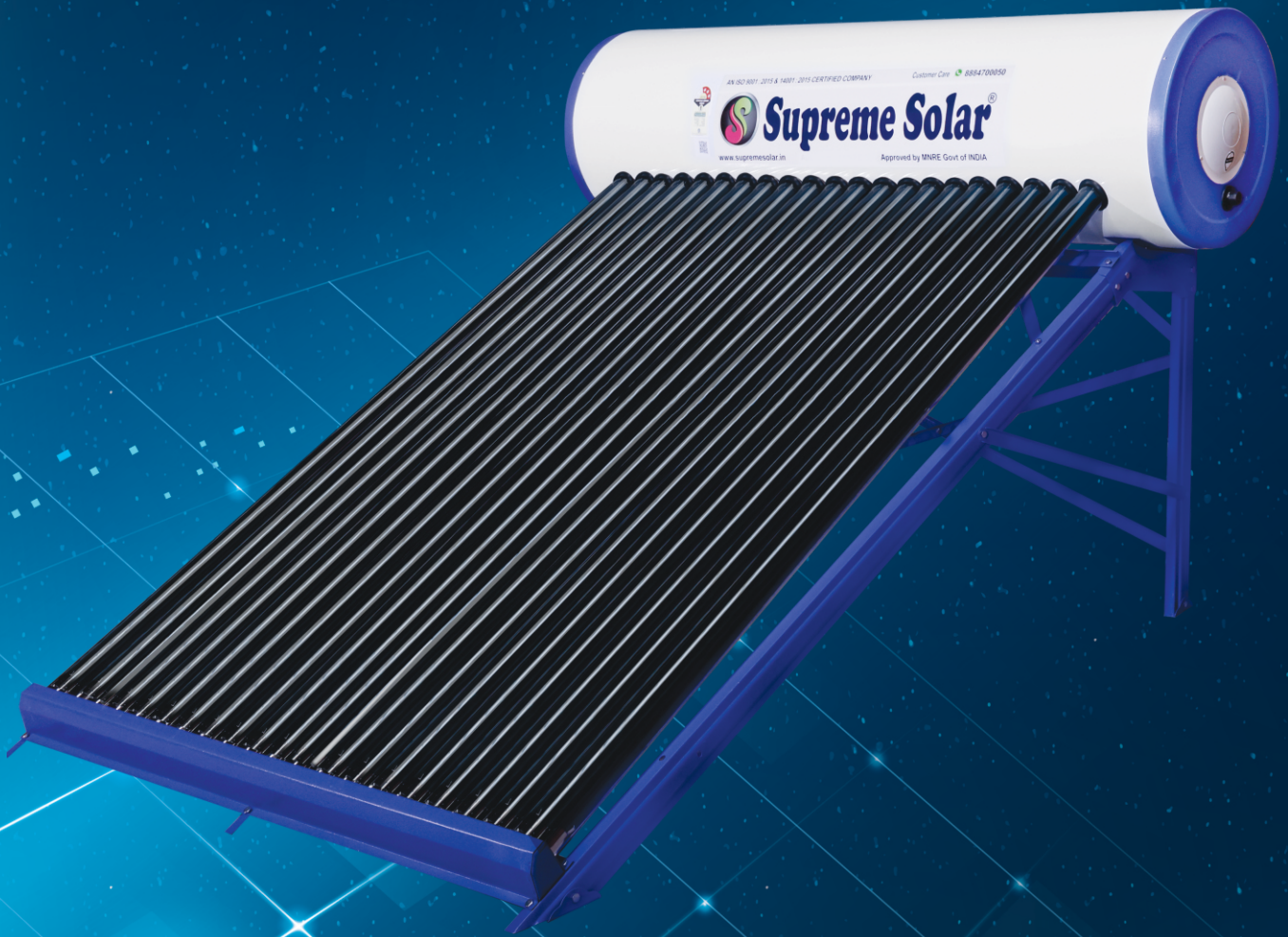



supreme
PRODUCTS
Make Life Better!

No. 1
SOLAR MANUFACTURER
IN INDIA

Quality Products
TIME TO

BLAM

Book Your
Order Today!



PRODUCTS

Geyser



Water Purifier



Chimney



ABOUT US

We have been established in 2004.
Based in Bangalore.



WWW.SUPREMESOLAR.IN

**SWITCH TO
SUPREME
PRODUCTS**

T A B L E O F C O N T E N T S

ABOUT THE PROPRIETOR	01	02
ABOUT OUR COMPANY	03	04
CERTIFICATIONS	05	06
SUPREME SOLAR WATER HEATER -ETC SOLAR MODELS -FPC SOLAR MODELS	07	18
SUPREME DCR & NON DCR MODULES	19	20
SUPREME HEAT PUMP SERIES	21	22
KITCHEN ELECTRIC RANGE HOOD	23	26
SUPREME WATER PURIFIER SERIES	27	30
SUPREME ELECTRIC GEYSER SERIES	31	32
SUPREME JAL WATER BOTTLE	33	34
SUPREME NATURE GRAINS CHAKKI FRESH ATTA	35	38
SUPREME SOUHARDA CREDIT CO- OPERATIVE SOCIETY LTD	39	42
SUPREME ASSOCIATE COMPANIES	43	44
SUPREME - INTERNATIONAL BRANCHES	45	46
GLIMPSE OF DISTRIBUTORS MEET - 2024	47	48
FRANCHISE / FACTORY	49	52

ABOUT THE MANAGING DIRECTOR



Mr. H. NARASIMHA PAI & Mrs. AJITHA PAI
MANAGING DIRECTOR

A visionary entrepreneur with a passion for innovation and excellence, Mr. H. Narasimha Pai (DME) has 21 years of experience in the industry. He has established a reputation for delivering high-quality products and services. Under his leadership, Supreme Solar has grown into a leading solar water heater manufacturing company, known for its commitment to quality, customer satisfaction, and community development.

Membership / Association:

-KASMA & STFI

Alongside his wife, Mrs. Ajitha Pai (B.E Mechanical), Mr. Pai has steered Supreme Solar towards unprecedented growth and success. Together, they have:- Established a strong presence in over 18 countries worldwide- Become one of the largest manufacturers of solar water heaters in India- Received prestigious awards, such as the **"Best Solar Water Heater Manufacturer"** award at the Renewable Energy India Awards- Collaborated with international organizations to promote sustainable energy solutions- Expanded product portfolio to include a range of solar PV solutions.

Today, Supreme Solar is recognized as a global leader in the renewable energy sector, with a reputation for innovation, quality, and customer satisfaction.

Mr. and Mrs. Pai's vision, leadership, and commitment to sustainability have been instrumental in driving the company's success, and their legacy continues to inspire future generations of entrepreneurs and environmental stewards.

"A Message from Our Managing Directors "

At Supreme Solar, we believe that renewable energy is the key to a sustainable future. As pioneers in the solar water heater industry, we have always been committed to providing innovative, high-quality solutions that make a positive impact on our customers' lives and the environment.

As we continue to grow and expand our presence globally, we remain dedicated to our core values of innovation, customer satisfaction, and sustainability. We are proud to have a talented team of professionals who share our vision and are passionate about making a difference.

We would like to take this opportunity to thank our valued customers, partners, and stakeholders for their continued support and trust in us. We look forward to continuing to serve you and contributing to a brighter, more sustainable future for all.

Sincerely,

Mr. H. Narasimha Pai & Mrs. Ajitha Pai

Managing Director, Supreme Solar

ABOUT THE DIRECTOR



Mr. Ganesh Pai M
Director, Supreme Solar

Mr. Ganesh Pai is a Director and industry expert with over 14 years of experience as a marketing director in Supreme Solar manufacturing company. He holds a diploma in Mechanical engineering and has completed various executive programs in business management.

Career Highlights:

- Marketing Head at Maruthi Dealer
- Franchise Partner of GE Money USA
- Marketing Director, Supreme Solar (Past 14 years)

Memberships In ,

- Ex-President of Karnataka Solar Manufacturing Association (KASMA), Members in different associations namely BNI, STFI, AIREA.
- Implemented various initiatives to promote sustainable energy practices and reduce carbon footprint.
- Participated in various Domestic as well as International Exhibitions to represent Supreme Solar namely , UAE, CAPE Town South Africa, Munich Germany, Atlanta City USA and Nepal.

Notable Awards & Recognition:

- Karnataka Business Award
- Best MSME Award (2024)

Under his visionary leadership, Supreme Solar continues to shine bright, illuminating the path to a sustainable future. Opened more than 70 Supreme franchises across India.

“A Message from Director”

At Supreme Solar, we're committed to empowering a sustainable future through innovative solar solutions. I'm proud of Supreme team's dedication to excellence and customer satisfaction. As we continue to grow and expand globally, we remain focused on delivering top-notch products and services that make a positive impact on our customers' lives and the environment.

Thank you for your continued support and trust in us - Mr. Ganesh Pai, Director, Supreme Solar

About Us

We have been established in year 2004, Supreme Solar has grown from a modest customer base to a trusted brand in India's domestic water heater market. We're recognized as one of India's top solar water heater companies, known for our quality and reliability.

As pioneers in ETC (Evacuated Tube Collectors) and FPC (Flat Plate Collectors) based solar water heaters, we've been driving the renewable energy revolution. Our mission is to empower millions to harness the benefits of solar power. Today, we're proud to have enabled lakhs of individuals to switch to solar water heaters. As a diversified company, Supreme Solar offers a portfolio of world-class products, including solar water heaters that excel in durability, performance, and innovation.

We launched, Glass-Lined Solar Water Heating Systems from 100LPD - 600LPD .world's best technology of present days. Internationally renowned technology for clean hot water.

Our other products are , Solar Rooftop Solutions, Electric Geysers, Heat Pumps, Kitchen Chimneys all under Supreme.

- * Supreme Nature Grains: Chakki Fresh Atta, Clear Whole Wheat Flour (introduced in 2024)
- * Supreme Jal Water Bottle Plant Jan , 2025
- * Supreme Souharda Credit Co-Operative Society Ltd: Established in 2024, providing specialized loans for solar energy projects.
- * Supreme Solar Pvt. Ltd., in partnership with CSIR-NAL, is excited to launched NALSUN-NG™ technology—the first, sprayable, eco-friendly graphene oxide-based coating for flat plate solar water heaters.

Management

Supreme Solar Systems is one of the leading companies operating as Manufacturer, Exporter, Wholesaler, Trader and Importer that deals with solar products such as Solar Water Heater, Kitchen Chimney, Hobs. Solar Lighting System, Electrical Storage Geyser, RO Purifier and Heat Pump.

Renowned for high quality and efficient functioning our products have been an innovative step in the concept of energy preservation and utility. Designed using the finest kind of raw material such as high-grade stainless steel, our products are greatly preferred by a large number of customers. Fabricated in exact compliance with industry norms, we are a government-approved enterprise working for almost a decade in this field.

Our expertise and experience in this industry have been possible due to the joint effort and team spirit of our members. We are a skilled group of professionals working together towards the common goal of offering high-quality solution-oriented power products for our valued customers. Our varied panel of manufacturing personnel, supply and logistics staff, administration and customer care unit all work in complete harmony to provide quality centric highly functional products for the customers.

Our enterprise has gained an outstanding position in the market thanks to the valuable guidance of Mr. H Narasimha Pai (Managing Director) who has enabled us to win the trust and loyalty of a number of esteemed patrons.



Over 5,000 dealers & distributors across India



Dealer network spanning 22 states in India

WHAT REALLY MATTERS TO OUR CUSTOMERS!!



Quality



Delivery



Cost



Service



Our Capabilities

We have set up a Large-scale solar energy product manufacturing unit, with Integrated scientific research, production, sales, and after-sales as a complete offering to our customers.

The core element of Supreme Products is to adapt advanced technology and international standards. Our products are well received in the home and commercial segments.

- In-house Research Team driving continuous improvement.

Quality Focus

Providing high-quality solar products with zero defects to ensure customer satisfaction.

Our Reach

Global presence with a strong foundation in India.

Manufacturing Excellence

State-of-the-art manufacturing plant spread across 11 acres land.

- Daily production capacity of **800** systems.
- Ranked among the top solar water heater manufacturing company in India.

Quality Policy

At Supreme Products, we are committed to achieving total customer satisfaction by supplying quality products on time. We achieve this through: Total involvement of employees- Compliance with quality management system requirements- Continual improvement of our processes.

Recognitions

Featured as a top solar water heater brand by the Indian Express.

Market Leadership: Strong presence in the Indian solar water heater market.

As per BRG UK Report Supreme Solar has been awarded No.1 Solar Water Heater Company in India.

Environmental Responsibility

Empowering customers to make environmentally conscious choices by adopting solar energy.

Certifications

Our products are certified by a range of international and local quality and product standards.

We introduce ourselves as a Manufacturer of Solar Thermal Systems for homes and Industrial applications. Our-Company is approved by Ministry of New and Renewable Energy (**MNRE**) - Government of India, New Delhi and we are one of their channel partners eligible for Capital Subsidy under **JNNSM** Scheme.

In addition, Our manufacturing facility is **ISO9001:14001**, **BIS** Certificate for ETC as well as **FPC**, **BEE Star Rating** Certificate, The First Indian Solar Company with **KEY MARK** International Standards Certificate from Germany. **Quality Management** certified. Test reports are available at our Supreme solar centre.

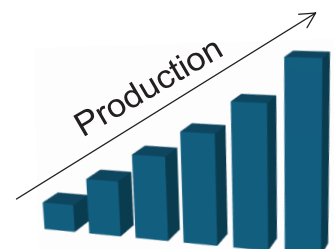

CERTIFICATIONS

DIN CERTCO
Gesellschaft für Konformitätsbewertung mbH

CERTIFICATE

Certificate holder Supreme Solar Projects Private Limited
D Cross Main Road
Plot No. 28-C, SY NO. 92, 93, 94 & 95
Veerapura Village, Kasaba Hobli
Doddaballapur 561203
INDIA

Production facility Bangalore

Product Solar collectors

Type, Model 2.045 m2 FLAT PLATE COLLECTOR

Testing basis DIN EN 12975:2022-06
DIN EN ISO 9806:2018-04
SOLAR KEYMARK Scheme Rules SKN N0444R7 (2024-01)

Mark of conformity

Registration No. 011-753232 F

Valid until 2029-05-31

Right of use This certificate entitles the holder to use the mark of conformity shown above in conjunction with the specified registration number.
See annex for further information.

2024-05-14
Dipl.-Biol. Katharina Vehring, M. Eng.
Certification Body

DIN CERTCO Gesellschaft für Konformitätsbewertung mbH - Albinstraße 56 - D-12103 Berlin - www.dincertco.de

DIN CERTCO
Gesellschaft für Konformitätsbewertung mbH

CERTIFICATE

Certificate holder Supreme Solar Projects Private Limited
D Cross Main Road
Plot No. 28-C, SY NO. 92, 93, 94 & 95
Veerapura Village, Kasaba Hobli
Doddaballapur 561203
INDIA

Production facility Bangalore

Product Solar collectors

Type, Model 1.5 m2 FLAT PLATE COLLECTOR

Testing basis DIN EN 12975:2022-06
DIN EN ISO 9806:2018-04
SOLAR KEYMARK Scheme Rules SKN N0444R7 (2024-01)

Mark of conformity

Registration No. 011-753231 F

Valid until 2029-05-31

Right of use This certificate entitles the holder to use the mark of conformity shown above in conjunction with the specified registration number.
See annex for further information.

2024-05-14
Dipl.-Biol. Katharina Vehring, M. Eng.
Certification Body

DIN CERTCO Gesellschaft für Konformitätsbewertung mbH - Albinstraße 56 - D-12103 Berlin - www.dincertco.de

ऊर्जा दक्षता ब्यूरो
(भारत सरकार, विद्युत विभाग)
BUREAU OF ENERGY EFFICIENCY
(Government of India, Ministry of Power)

Brand : Supreme Solar
Model Name/ Number : ETC GL
Year of Manufacturing : 2024

5. Details of the Equipment

Application ID	173990
Brand Name	Supreme Solar
Technology	Evacuated tube collectors
System Efficiency	64
Capacity (in LPD)	220
Year Of Manufacturing	2024

6. Label Details

Name of the manufacturer/importer/brand	Supreme Solar
Model / Year of manufacturing	ETC GL / 2024
Star level	3
Technology	Evacuated tube collectors
Capacity (in LPD)	220
Country of Origin	India
Label period	14-12-2019 - 31-12-2024
Unique label series code	BEE/SUP/24/006/24

POWER SAVING GUIDE

ENERGY EFFICIENCY
System Efficiency (η_{sys}) 64%
Label Period: 14th Dec 2019 - 31st Dec 2024

The QR Code on the approval letter is recommended to be placed just below the star label being affixed on each unit of the appliance.

The unique label series code provided in the letter has to be mentioned in the label affixed on the Solar Water Heater.

7. The label design, size, colour scheme, material to be used for the label and the content of the label and colour scheme of the Bureau's logo shall be as specified in the Schedule to these regulations.

8. Specimen of the label duly approved by the Bureau to be affixed on the Solar Water Heater is shown above.

संविदा एवं संचालित में ऊर्जा बचाव Save Energy for Benefit of Self and Nation
पौधा पर, सेवा मान, ऊर्जा को नष्ट नहो, नई दिल्ली-110 086 वेबसाइट/ Website : www.beeindia.gov.in 03-04-2024 13:08:33
4th Floor, Sewa Bhawan, R.K. Puram, New Delhi-110 086 ईमेल/ Tel.: 91 (11) 26766700, फ़ैक्स/ Fax: 91 (11) 26178352

1. Authentication of Vendor Profile

Parameters	Requirements	Responses
Company Description/Details	Name of the Company/Firm	SUPREME SOLAR PROJECTS PRIVATE LIMITED
	Registered Address	Plot No. 28-C, SY NO. 92, 93, 94 & 95, Doddaballapura Main Road, Veerapura Village Kasaba Hobli, Bangalore, Karnataka, 561203
	Address of Manufacturing Site	Plot No. 28-C, SY NO. 92, 93, 94 & 95, KIADB Industrial Area, Veerapura Village Kasaba Hobli, Doddaballapura, Bengaluru, Karnataka 561203
	Primary Contact Number	9902772277
	Primary Email ID	supremenippon@gmail.com
	Additional Contact Number	900894500
	Additional Email ID	pavan@supremesolar.in
	Constitution	company
	Company Identification Number	U29100KA2016PTC092584
	Date of Incorporation of the Company	27/04/2016
Banking Details	GST Number (Company)	29AAXCS0239B1Z6
	PAN of the Company	AAXCS0239B
	Company debarred/blacklisted by any Govt. organisation	No
	Bank Name	HDFC BANK, BANGALORE - INDIRA NAGAR
Details of Products Registered for VA	Account Holder Name	Supreme Solar Projects Pvt Ltd
	Account Number	57500000742333
	IFSC code	HDFC0000184
Details of Products Registered for VA	Quality Certification	Yes
	Other License Number (if applicable)	No



भारतीय मानक ब्यूरो
Bureau of Indian Standards
The National Standards Body of India

For any other communication

Address: Bengaluru Branch Office-
Peenya Industrial Area, 1st
Stage, Bengaluru - Tumkur
Road, Bangalore, BANGALORE
RURAL,KARNATAKA,560058
Phone: 08028394955
Fax: 08028398841
E-Mail: bnbo@bis.gov.in
Web: www.bis.org.in,
www.manakonline.in

Our Ref :BNBO/CM/L 6200210780

Dated:
25-07-2024

Subject: Grant of BIS Certification Marks Licence No 6200210780 as per IS 16544:2016
M/S SUPREME SOLAR PROJECTS PVT LTD
Plot No 28C, KIADB Veerapura Village, Kasaba Hobli, Doddaballapura Industrial Area, Bangalore
Rural,BANGALORE,DODBALLAPURA,BANGALORE RURAL,KARNATAKA,INDIA 561203

Dear Madams(s)/Sir,

With reference to your application, we are pleased to inform you that the Certification Marks Licence has been granted to you to use the Standard Mark in respect of the followings:

ALL GLASS EVACUATED TUBES SOLAR WATER HEATING SYSTEM

Product:-

Grade/Class/Type/Variety

1.All Glass Evacuated Tubes Solar Water Heating System, Capacity=150 LPD, Collector Area=2.25 m2, Number of Evacuated Tubes=15, Outer Diameter of Evacuated Tubes= 58 mm, Length of Tubes=1800 mm, Material of Tank=Mild Steel Sheet conforming to IS 1079 with Enamel Lining, Material of Tubes=Borosilicate Glass.2. All Glass Evacuated Tubes Solar Water Heating System, Capacity=200 LPD, Collector Area=3.55 m2, Number of Evacuated Tubes=20, Outer Diameter of Evacuated Tubes= 58 mm, Length of Tubes=1800 mm, Material of Tank=Mild Steel Sheet conforming to IS 1079 with Enamel Lining, Material of Tubes=Borosilicate Glass

1. The licence is granted on the explicit condition that you will mark entire/substantial production which conforms to the Indian Standards.

2.The number assigned to this licence is CM/L- 6200210780 which has been made operative from 2024-07-21 and is valid upto 2025-07-20. The licence number should invariably be referred to in your future correspondence.

According to sub-regulation (1) &(3) of Paragraph 5 of scheme I of Schedule II under Bureau of Indian Standards (Conformity of Assessment) Regulation, 2018, the annual licence fee of Rs. 1000.00 and the marking fee for use of standard mark as per Annexure-I of Scheme I of BIS(Conformity assessment) Regulation 2018 is payable by you with effect from 2024-07-21 for the period of validity of the licence in advance.

3. Minimum marking fee stipulated in Annexure -1 of scheme I of BIS (Conformity Assessment) Regulation 2018 is payable by you regardless of the whether you actually mark your product or not with the Standard Mark.**Our Receipt**



भारतीय मानक ब्यूरो
Bureau of Indian Standards
The National Standards Body of India

For any other communication

Address: Bengaluru Branch Office-Peenya
Industrial Area, 1st Stage, Bangalore
- Tumkur Road, Bangalore,
BANGALORE
RURAL,KARNATAKA,560058
Phone: 08028394955
Fax: 08028398841
E-Mail: bnbo@bis.gov.in
Web: www.bis.org.in, www.manakonline.in

BUREAU OF INDIAN STANDARDS

Attachment to Licence No. CM/L- 6200092699

CM/L-No	Name of the Licensee with the Factory Address	Name of the Product	Indian Standard No.
6200092699	SUPREME SOLAR PROJECTS PVT LTD -UNIT-II,SY NO 92,93,94 & 95, PLOT NO.28 C, VEERAPURA VILLAGE, DODDABALLAPURA INDUSTRIAL AREA, DODDABALLAPURA, BANGALORE : 561203	Solar Flat Plate Collector - Part I : Requirements	IS 12933 : PART 1 : 2003

Endorsement No. 7 Dated 03-Aug-2024

Whereas, the licence was valid upto Eighth August Two Thousand Twenty Four.

Now, consequent upon renewal, the validity of the licence given in schedule of the Licence Dated 07-AUG-2024 has been extended from Eighth August Two Thousand Twenty Four to Seventh August Two Thousand Twenty Five

Other terms and conditions of licence remain same.

Branch Head (Bengaluru Branch Office)

Manak Bhavan, 9 Bahadur Shah Zafar Marg, New Delhi 110002. 9 Bahadur Shah Zafar Marg, DELHI,110002

Contact No : +91 11 23230131, 23233375, 23239402

Fax : +91 11 23234062, 232

Email : info@bis.gov.in



Certificate of Compliance

INTEGRATED QUALITY CERTIFICATION PRIVATE LIMITED
hereby certifies that the Quality Management Systems of
SUPREME SOLAR PROJECTS PRIVATE LIMITED

#687, 1st floor, 3rd Cross, Opp. Seshadripuram College,
MIG Sector A, Yehalanka Satellite Town, 3rd Stage,
Extension Yelahanka, Bangalore - 560064.
Plot No: 28-C, Sy No. 92, 93, 94 & 95, Veerapura Village,
Kasaba Hobli, Doddaballapura Industrial Area,
(KIADB), Bangalore - 561 203.

has been assessed and conforms to the
Quality Management Systems
ISO 9001:2015

Scope: Manufacture and supply of solar water heating systems.
Manufacture, assembly and supply of water purifiers and Geysers.
Trading of electrical chimney, heat pumps, pressure pumps,
solar PV panels and air conditioner.

Subdivision	: 24, 34	Initial issue date	: 27.04.2014
Class	: 2452, 3499	Current issue date	: 02.05.2023
Process(es) not applicable	: 8.3	Current expiry date	: 26.04.2026
Certificate number	: IND/IMS-QE/IAS-C0011/RC4/0978	1st Surveillance due	: 02.05.2024
Attachment(s)	: None	2nd Surveillance due	: 02.05.2025

Suma Shankar
Suma Shankar
Director

Certificate of compliance has an expiry period of 3 years from the current certification cycle start date but shall be considered as expired if the surveillance audit programme indicated in this certificate of compliance is not implemented to maintain confidence that the certified management system continues to fulfil requirements unless otherwise supported by a letter of continued compliance issued by the registered office of Integrated Quality Certification Pvt. Ltd. Certificate of compliance shall be updated in website/registry as suspended and/or withdrawn if the surveillance programme prior to the due date indicated above is not coordinated and implemented. Written information on any significant organizational changes with impact on the certificate of compliance shall be communicated to Integrated Quality Certification Pvt. Ltd prior to the planned audit schedule.

Corporate Office : Platinum City, G/13/03, Site # 02, Next to CMTL HMT Road, Yeshwanthpur Post, Bangalore - 560 022, India.
Tel : +91(80) 41172752, 41277353, 41280342. Email : iqccorporate@iqcglobal.com Website : www.iqcglobal.com.
CN : U7140KA2003PTC01851.

Please visit www.iqcglobal.com to verify the authenticity and validity of this certificate of compliance
QI-15A Rev 00 date 04.12.2019



Certificate of Compliance

INTEGRATED QUALITY CERTIFICATION PRIVATE LIMITED
hereby certifies that the Environmental Management Systems of
SUPREME SOLAR PROJECTS PRIVATE LIMITED

#687, 1st floor, 3rd Cross, Opp. Seshadripuram College,
MIG Sector A, Yehalanka Satellite Town, 3rd Stage,
Extension Yelahanka, Bangalore - 560064.
Plot No: 28-C, Sy No. 92, 93, 94 & 95, Veerapura Village,
Kasaba Hobli, Doddaballapura Industrial Area,
(KIADB), Bangalore - 561 203.

has been assessed and conforms to the
Environmental Management Systems
ISO 14001:2015

Scope: Manufacture and supply of solar water heating systems.
Manufacture, assembly and supply of water purifiers and Geysers.
Trading of electrical chimney, heat pumps, pressure pumps,
solar PV panels and air conditioner.

Subdivision	: 24, 34	Initial issue date	: 27.04.2014
Class	: 2452, 3499	Current issue date	: 02.05.2023
Process(es) not applicable	: None	Current expiry date	: 26.04.2026
Certificate number	: IND/IMS-QE/IAS-C0011/RC4/0033	1st Surveillance due	: 02.05.2024
Attachment(s)	: None	2nd Surveillance due	: 02.05.2025

Suma Shankar
Suma Shankar
Director

Certificate of compliance has an expiry period of 3 years from the current certification cycle start date but shall be considered as expired if the surveillance audit programme indicated in this certificate of compliance is not implemented to maintain confidence that the certified management system continues to fulfil requirements unless otherwise supported by a letter of continued compliance issued by the registered office of Integrated Quality Certification Pvt. Ltd. Certificate of compliance shall be updated in website/registry as suspended and/or withdrawn if the surveillance programme prior to the due date indicated above is not coordinated and implemented. Written information on any significant organizational changes with impact on the certificate of compliance shall be communicated to Integrated Quality Certification Pvt. Ltd prior to the planned audit schedule.

Corporate Office : Platinum City, G/13/03, Site # 02, Next to CMTL HMT Road, Yeshwanthpur Post, Bangalore - 560 022, India.
Tel : +91(80) 41172752, 41277353, 41280342. Email : iqccorporate@iqcglobal.com Website : www.iqcglobal.com.
CN : U7140KA2003PTC01851.

Please visit www.iqcglobal.com to verify the authenticity and validity of this certificate of compliance
QI-15B Rev 00 date 04.12.2019

TOP Home Appliance SOLAR WATER HEATER SERIES

SUPREME ETC MODEL

SOLAR WATER HEATER(SS)



Three coated
Vacuum tube

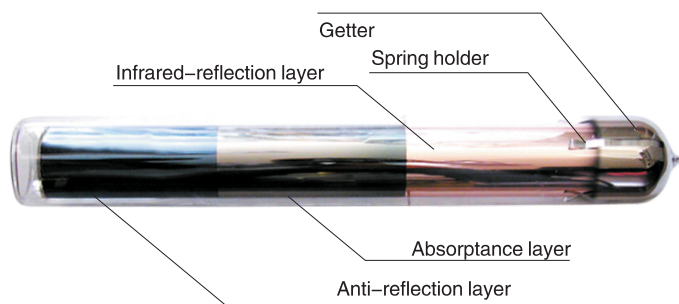
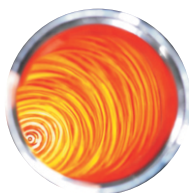

TOP Home Appliance SOLAR WATER HEATER SERIES



Switch on the sun

Free hot water for life

**Govt. Approved
Company**

SUPREME ETC MODEL

SOLAR WATER HEATER(PC)

- **Supreme Solar SS ETC 304L Grade model** suitable for water hardness up to **300 PPM**
- **Supreme Solar SS 316L Grade ETC model** suitable for water Hardness up to **1000 PPM**
- **Supreme Solar Copper ETC model** suitable for water hardness up to **1200 PPM**
- **Supreme Solar GL ETC model** Suitable for water hardness up to **4000 PPM**
- **Please test water Hardness before Installing solar Water Heater**

Technical Specifications

Type of collector	:	ETC
Specifications	:	58-1800mm
Frame angle	:	27 Degrees
Inner tank materials	:	High grade materials
Insulation	:	High quality PUF materials
Tank Volume	:	100Ltrs - 500Ltrs
Outer tank	:	Powder coated / Stainless steel



TOP Home Appliance SOLAR WATER HEATER SERIES



SUPREME ETC GLASS-LINED MODEL

SOLAR WATER HEATER(SS)

APPROVED BY
20 YEARS GUARANTEE
MNRE. Govt. of India

Technical Specifications

Types of collector	: ETC
Specifications	: 58 - 1800mm & 58 - 2100mm
Frame Angle	: 27 Degrees / 45 Degrees
Inner Tank Materials:	Enamel Steel of 2mm & 2.5 mm With Glass Lined Coating.
Tank volume	: 110L - 600 Ltrs
Outer Dish	: Galvanised With Powder Coated.
Insulation	: 50 mm High Quality PUF Materials.
Outer Tank	: Powder Coated / Stainless Steel.



TOP Home Appliance SOLAR WATER HEATER SERIES

SUPREME ETC GLASS-LINED MODEL

SOLAR WATER HEATER(PC)

APPROVED BY

**20 YEARS
GUARANTEE**

MNRE. Govt. of India



Technical Specifications

Types of collector : ETC
 Specifications : 58 - 1800mm & 58 - 2100mm
 Frame Angle : 27 Degrees / 45 Degrees
 Inner Tank Materials: Enamel Steel of 2mm & 2.5 mm
 With Glass Lined Coating.
 Tank volume : 110L - 600 Ltrs
 Outer Dish : Galvanised With Powder Coated.
 Insulation : 50 mm High Quality PUF Materials.
 Outer Tank : Powder Coated / Stainless Steel.

Glass Lined System (Porcelain Enamel)	Tube size	Number of Tubes	Number of Users
110 LPD GL	58-1800	11	2
165 LPD GL	58-1800	16	3
200 LPD GL	58-1800	20	4
220 LPD GL	58-1800	21	4
270 LPD GL	58-1800	26	5
300 LPD GL	58-1800	30	6
400 LPD GL	58-2100	34	7
500 LPD GL	58-2100	32	8
500 LPD GL	58-2100	38	8
600 LPD GL	58-2100	38	10

TOP Home Appliance SOLAR WATER HEATER SERIES



SUPREME ETC GLASS-LINED MODEL

Full Stainless Steel Model

Suitable for all type of water



Technical Specifications

- Types of collector : ETC
- Specifications : 58 - 2100mm
- Frame Angle : 27 Degrees
- Inner Tank Materials: Enamel Steel of 2mm & 2.5 mm
With Glass Lined Coating.
- Tank volume : 110L, 165L, 200L, 220L, 270L, 300L, 400L, 500L & 600LPD
- Outer Dish : Stainless Steel.
- Insulation : 50 mm High Quality PUF Materials.
- Outer Tank : Stainless Steel.





SUPREME SOLAR SS ETC 304L GRADE MODEL

Supreme HEAVY ETC Full Stainless Steel with Assistant Tank Model Solar Water Heaters

Suitable for water hardness up to 300PPM



Technical Specifications

- Types of collector : ETC
- Specifications : 58-1800mm
- Frame Angle : 27 Degrees
- Inner Tank materials : High Grade Materials
- Insulation : High Quality PUF Materials.
- Tank Volume : 100L - 500 Ltrs
- Outer tank : Stainless Steel.
- Number of Persons to use : 3 - 18 Persons

TOP Home Appliance
SOLAR WATER HEATER SERIES



SUPREME ETC GLASS-LINED SLEEPER MODEL

SOLAR WATER HEATER

APPROVED BY
20 YEARS
GUARANTEE
MNRE. Govt. of India



TOP Home Appliance SOLAR WATER HEATER SERIES

SUPREME ETC GLASS-LINED SLEEPER MODEL

SOLAR WATER HEATER(PC)



APPROVED BY
20 YEARS GUARANTEE
MNRE. Govt. of India

Technical Specifications

Types of collector	: ETC
Specifications	: 58 - 1800mm & 58 - 2100mm
Frame Angle	: 27 Degrees / 45 Degrees
Inner Tank Materials:	Enamel Steel of 2mm & 2.5 mm With Glass Lined Coating.
Tank volume	: 110L - 600 Ltrs
Outer Dish	: Galvanised With Powder Coated.
Insulation	: 50 mm High Quality PUF Materials.
Outer Tank	: Powder Coated / Stainless Steel.

Glass Lined System (Porcelain Enamel)	Tube size	Number of Tubes	Number of Users
110 LPD GL	58-1800	11	2
165 LPD GL	58-1800	16	3
200 LPD GL	58-1800	20	4
220 LPD GL	58-1800	21	4
270 LPD GL	58-1800	26	5
300 LPD GL	58-1800	30	6
400 LPD GL	58-2100	34	7
500 LPD GL	58-2100	32	8
500 LPD GL	58-2100	38	8
600 LPD GL	58-2100	38	10



supreme
PRODUCTS
Make Life Better!

SOLAR WATER HEATER SERIES

VAJRA MODEL

HEAT PIPE HEAT EXCHANGER (PRESSURISED)

330L

DAY & NIGHT

SYSTEM

WORLD'S BEST TECHNOLOGY

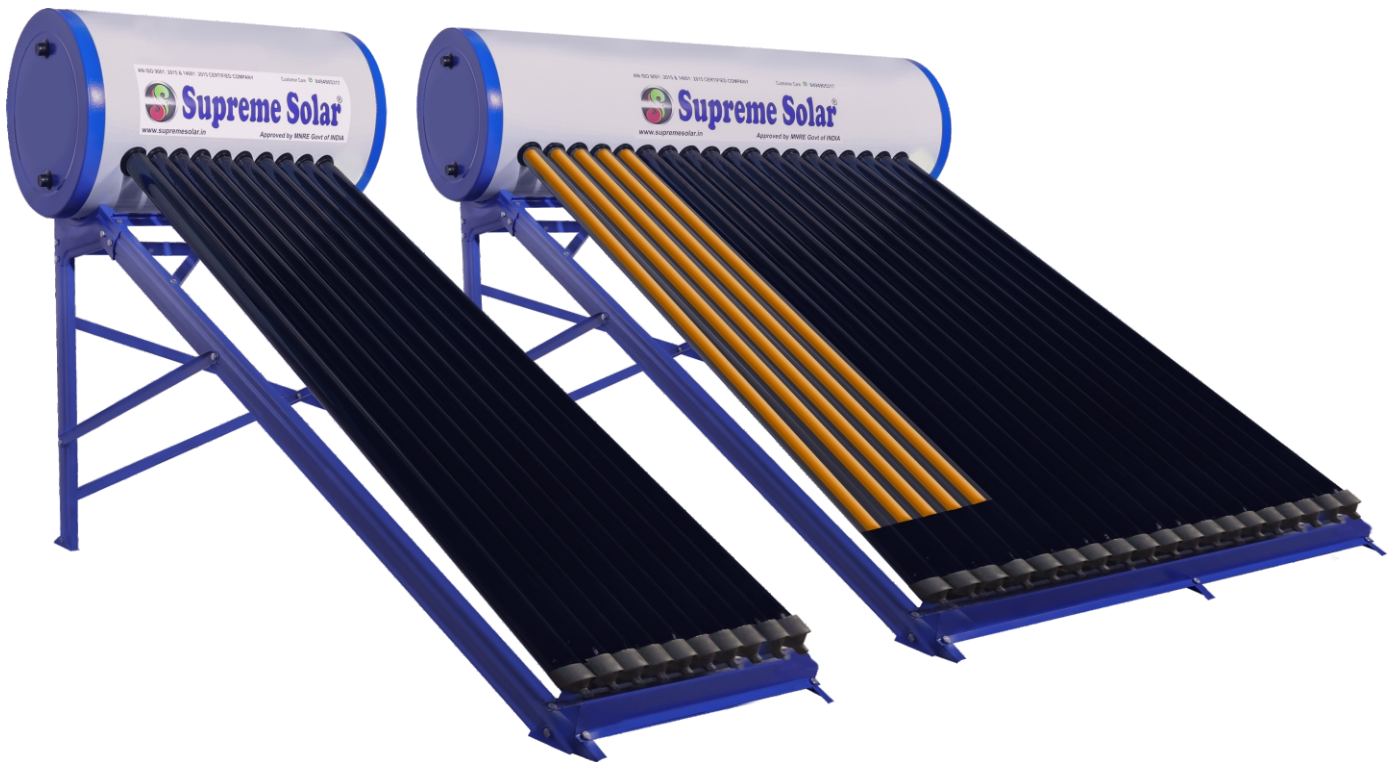

TOP Home Appliance SOLAR WATER HEATER SERIES

HEAT PIPE HEAT EXCHANGER , Introduced for the first time in India by **Supreme Solar**® to get better temperature in cloudy conditions by using pressure booster pumps. with stands high pressure of water VAJRA Model enhances efficacy by 20%



TESTED BY PUNE UNIVERSITY

Technical Specifications

Type of collector	: ETC
Specifications	: 58 - 2100 mm
Frame angle	: 27 Degrees
Inner tank materials	: Enamel steel of 3 mm With glass lined coating
Outer tank	: Powder coated / Stainless steel
Inner dish	: 3 mm
Outer dish	: Aluminum with powder coated
Insulation	: 50mm high quality PUF materials

- | | |
|---|--|
| <p>1 Doors Provided for cleaning purpose</p> <p>3 High-Pressure High-Density PUF Insulation
Keeps water warm for longer</p> <p>5 Special Profile Rolled Section Stand
Provides stability and strength to the system</p> | <p>2 Glass Lined Coating to avoid rust</p> <p>4 Capsule Dish-End-Shaped Tank
Withstands greater pressure</p> <p>6 3T Gold Standard Tubes
Gives you maximum hot water</p> |
|---|--|

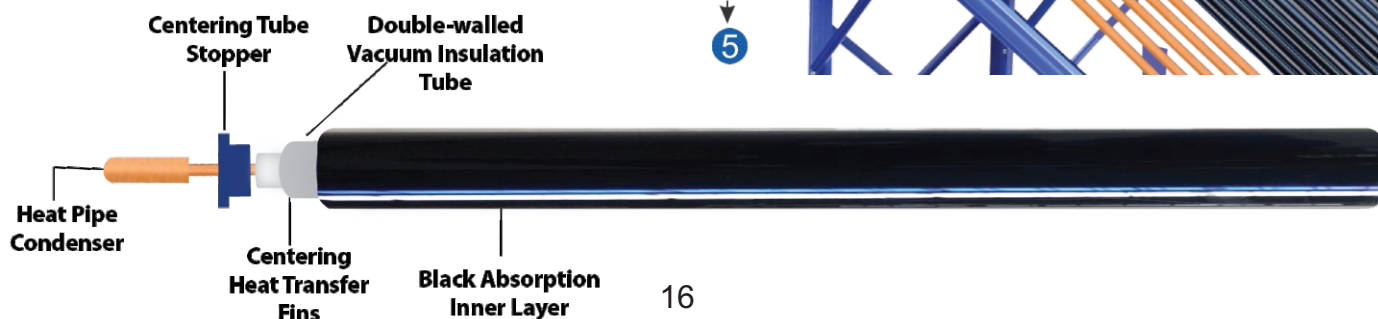
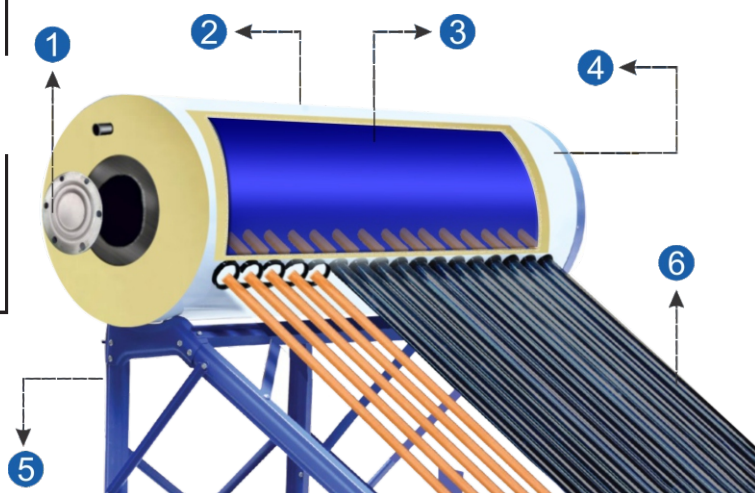

TOP Home Appliance SOLAR WATER HEATER SERIES



SUPREME FPC MODEL

SOLAR WATER HEATER(PC)

Technical Specifications

Section	: 1.2mm thick aluminium
Back sheet	: 0.46mm thick aluminium
Insulation	: Fiber glass wool
Flat plate collector	: Ultrasonic welded with nalsun coating
Header pipe	: Cooper 24 SWG
Glazing	: 1000X2000X4mm clear toughened glass
Fasteners	: Stainless steel
Grommets	: E.P.D.M rubber
Flanges	: Brass
Finishing	: Powder coating / Stainless Steel
Strong tank	
Inner tank	: C.R.C.A sheet with prime guard coating
Insulation	: 50mm thick PUF
Support structure	: Mild steel with powder coating
Capacity available	: 110 LPD to 300 LPD Glass Lined 500 LPD to 2500 LPD Ceramic

**Govt. Approved
Company**

Switch on the sun

Free hot water for life



CM/L-6200092699

Renewable Energy is **Green,** Clean & Sustainable Energy

SUPREME FPC MODEL

Jacket Type Heat Exchanger Model

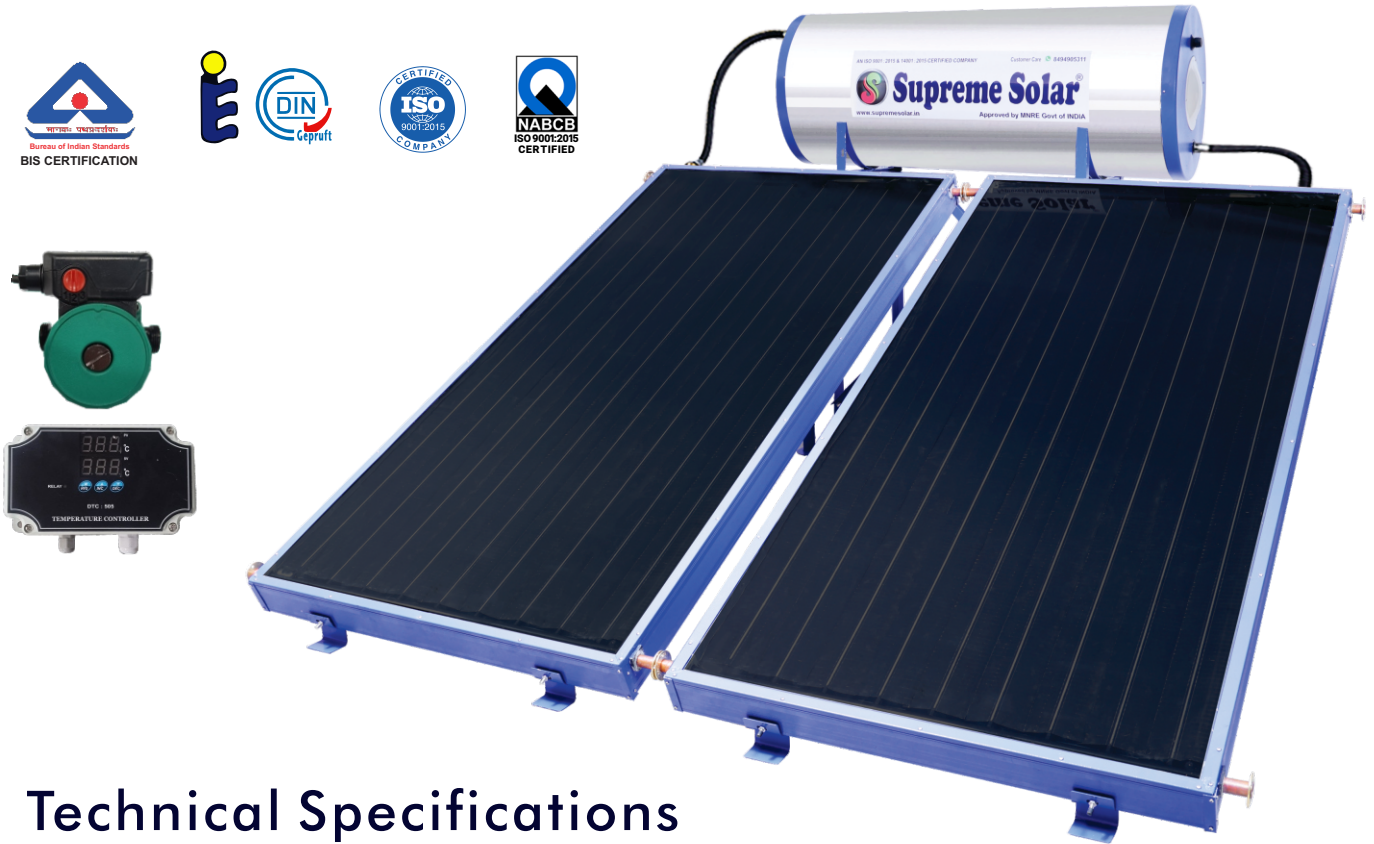

Technical Specifications

Inner tank Material	: 3 mm CRCA with Porcelain Enamel Coating
Jacket Material	: 1.5 mm CRCA
Outer Tank	: 0.4 mm Pre Coated / 0.3 mm Stainless Steel
Inner Dish	: 3 mm CRCA with Porcelain Enamel Coating
Heat Transfer Carrier (medium)	: Glycol in the Jacket
Temperature	: 60 degree C to 85 degree C.
Tank Insulation	: PUF 50 (Polyurethane foaming)
Stand frame	: GI Polyester Powder coated
Method of Welding	: Straight and Plasma Welding Technology.
Type of Fasteners	: Stainless Steel (Galvanised)
Inlet Outlet Pipes	: Low Carbon Steel
Type of Grommets	: EPDM (washers)
Type of Circulation	: Forced Flow
Electrical Back Up	: Optional

BENEFITS:

- Save Up to 70% on your Electricity Bill
- Eco Friendly
- Extended Life of more than 20 years
- Low maintenance
- One time Investment, Life long Benefit
- Scale Guard for hard water
- Anti Freeze in cold region



SUPREME SOLAR DCR & NON DCR PV MODULES

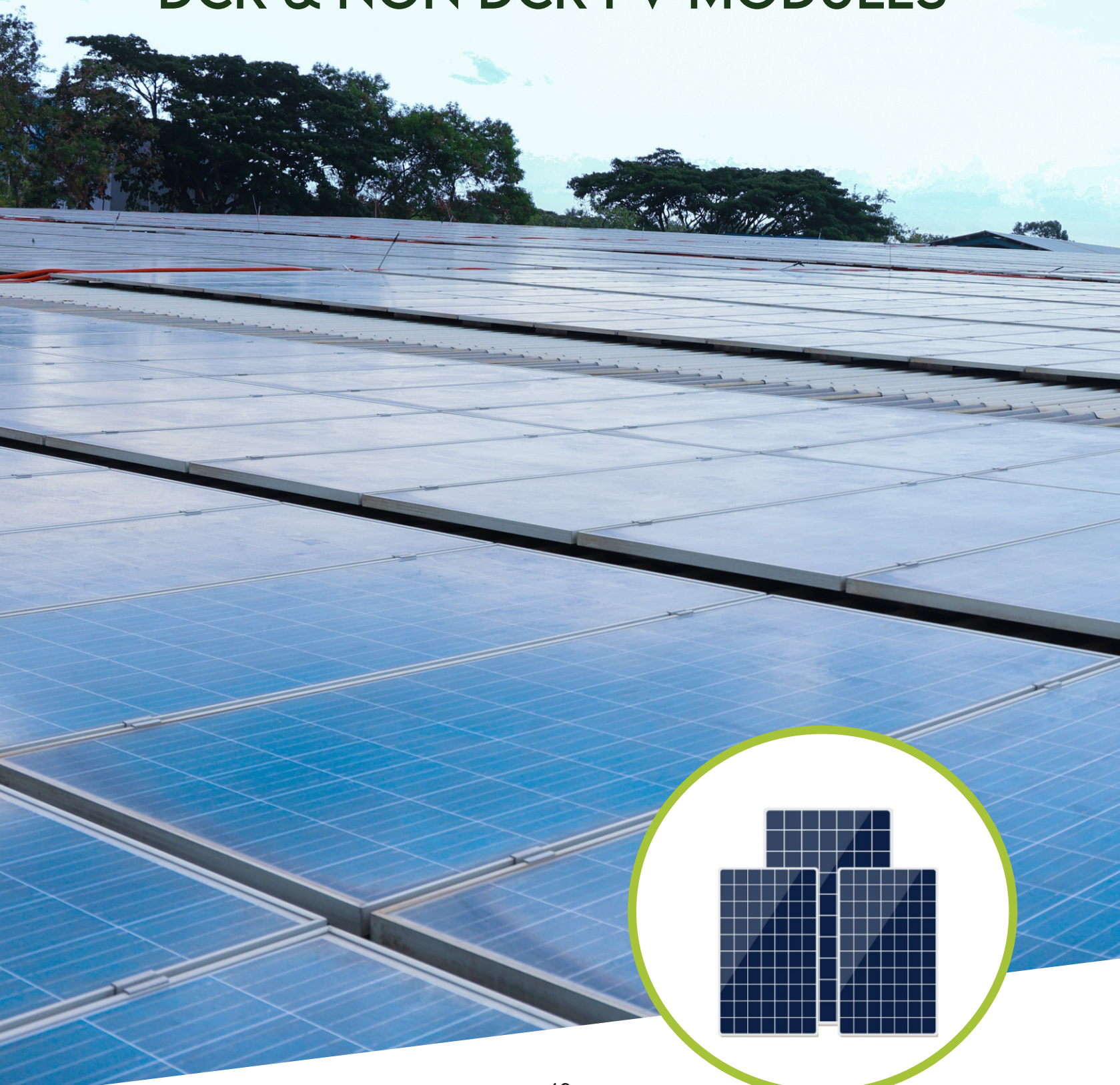



Consider our Solar solutions & Save on your  **Electricity Bill !!**



TOP Home Appliance SUPREME HEAT PUMP SERIES



SUPREME HEAT PUMP SERIES

BENEFITS OF SUPREME HEAT PUMP

- 24/7 Hot water availability.
- Saves 70% to 80% of energy when compared to traditional heating methods.
- Reduce the CO2 emission.
- Fully saving compared to traditional combustion heating.
- Works in any type of climate.
- Easy and flexible installation.
- It can be clubbed with the existing solar system/ diesel fired boiler as a hybrid solution.
- Requires less area for installation.
- Durability: long life span with least maintenance.
- Equipped with fully automatic and intelligent controllers and no needs human attention once commissioned.
- Supreme Heat Pump is Service Friendly and we can get all spare parts in any local markets all over India.





'Make your day'
Start with a **HOT** Bath

WORKING OF A HEAT PUMP:

A mixture of water and anti-freeze is pumped around the ground loop and absorbs the naturally occurring heat stored in the ground. The water mixture is compressed and goes through a heat exchanger, which extracts the heat and transfers it to the heat pump. The heat is then transferred to your home heating system.



Capacity Available
100 LPH
150 LPH
220 LPH
250 LPH
350 LPH
550 LPH
1100 LPH

TOP Kitchen Electric
Range Hood



Wall Mounted Glass Series



TOP Kitchen electric
Range Hood

**Exquisite craft
& Aesthetic design**

Intelligent products designed, advanced technology & complete guarantee, bring you a healthier cooking area.

Bring the *Sparkle* back into your kitchen!



Ratings



Government of India
Ministry of New and Renewable Energy
Renewable Energy is Green, Clean and Sustainable



Tested by Pune university

We the supreme Solar Systems team is strongly committed and dedicated to achieve total customer satisfaction by supplying quality products on time. This is achieved through total involvement of employees and complying with quality management system requirements and continually improving its effectiveness.



MAKE MAGIC IN YOUR KITCHEN

TOP Kitchen Electric
Range Hood
Wall Mounted Glass Series

**SUPREME
FLAMES**
(AN ISO 9001:2008 & ISO 14001:2004 Certified Company)



EXQUISITE CRAFT & ELEGANT
APPEARANCE



FLORA SX / 60 cm

SSS H5 60
 With Auto Clean
 Double cone filter with oil cup
 3 speed touch switch
 Air flow : 1050 60 m³/hr

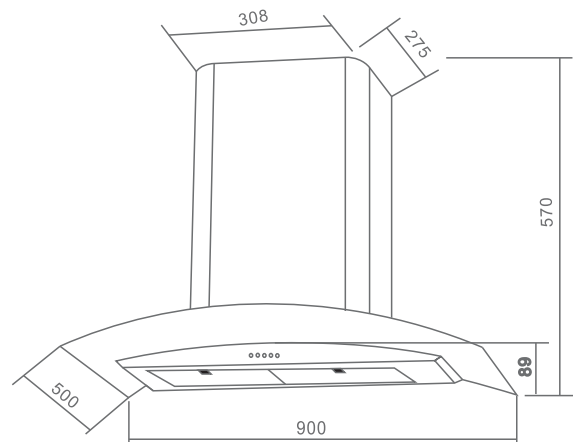

TOP Kitchen Electric Appliances Water Purifier Series



0% Water Wastage
Ro Technology



Double Purification By
Ro + Uv + Uf With Tds
Controller



Removes Even Dissolved
Impurities While Retaining
Essential Minerals



High Recovery Rate
Ro Water Purifier



Equally Suitable For Water
From All Sources Such As
Bore-wells, Tanks Or Tap-water



Computer Controlled Operation
With Filter Change And Uv Fail
Alarms



Food Grade, Non-breakable,
Abs Plastic Construction

TOP Kitchen Electric Appliances Water Purifier Series



SUPREME AQUA DELTA

- Advanced RO Technology + Alkaline 12th stage purification
- Wall mount and transparent water level indicator
- 13Ltrs storage tank capacity
- Inbuilt storage tank
- Suitable for all type of raw water
- Works up to 1600 TDS
- Fully automatic water level sensor with auto start /Auto off
- UV UF TDS with mineral cartridge + Alkaline cartridge (optional Copper Cartridge inline if required)

SUPREME AQUA MAGNA

- Advanced RO Technology + Alkaline 12th stage purification
- Wall mount and transparent water level indicator
- 18Ltrs storage tank capacity
- Inbuilt storage tank
- Suitable for all type of raw water
- Works up to 2400 TDS
- Fully automatic water level sensor with auto start /Auto off
- UV UF TDS with mineral cartridge + Alkaline (optional Copper if required)





SUPREME AQUA PRIME

- Advanced RO Technology + Alkaline
- 12th stage purification
- Wall mount with water level Indicator
- 10Ltrs storage tank capacity
- Inbuilt storage tank
- Suitable for all type of raw water
- Works up to 2400 TDS
- Fully automatic water level sensor with auto start /Auto off
- UV UF TDS with mineral cartridge + copper cartridge (optional)



SUPREME AQUA CORAL

- Advanced RO Technology + Alkaline
- 12th stage purification
- Wall mount and transparent water level indicator
- 15Ltrs storage tank capacity
- Inbuilt storage tank
- Suitable for all type of raw water
- Works up to 2400 TDS
- Fully automatic water level sensor with auto start /Auto off
- UV UF TDS with mineral + Alkaline (optional Copper cartridge inline if required).



TOP Kitchen Electric Appliances
Water Purifier Series



BETTER Pure water for
HEALTH



TOP Home Appliance ELECTRIC GEYSER SERIES



ELECTRIC GEYSER SERIES



SPWH-25 VERTICAL

Volume - 25 Ltrs

Power - 2000 watts

Voltage / Frequency (V) - 230 / 50

Temperature Range - 25C to 75C

Rated Water Pressure (Mpa) - 0.6 & 0.8

Product Dimensions (D*L) - 340*530

Product Warranty - 2 years



**ELECTRIC
GEYSER
SERIES**

SUPREME JAL WATER BOTTLE UNIT-2 BANGALORE

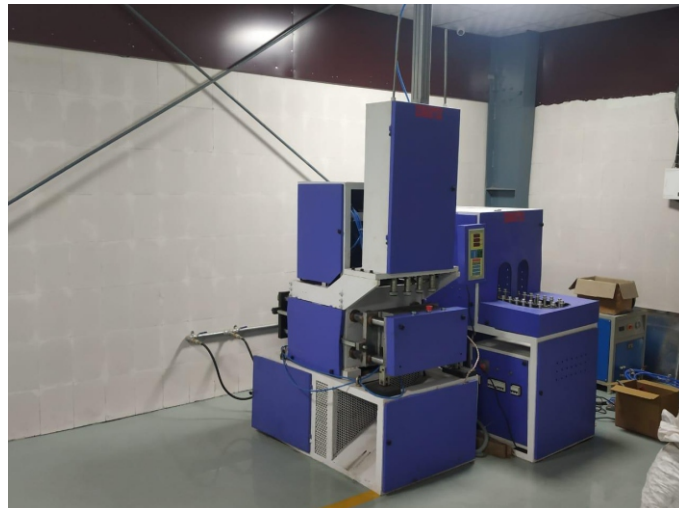

SUPREME JAL WATER BOTTLE



supreme
introducing a **jal**
water bottle



Sugar Control
0% Maida, 100% Atta

Chakki Fresh Atta
Clear whole wheat flour



Fresh & Delicious

☎ 88844 41039



www.supremedeliciousfoods.com

MAKE MAGIC IN YOUR KITCHEN





BENGAURU



**NATURE
GRAINS**



To project and promote our brand **Nature grains** across the country our bahubali fame and very elegant **Mrs. Ramya Krishnan** is our brand ambassador....!



SUPREME SOUHARDA CREDIT CO-OPERATIVE SOCIETY LTD.,

NO: R C S/R S R/SOUHARDA/REG/55/6061/2022-23



Supreme Dhanalakshmi Savings Bond (7 Years)

Amount (₹)	Months	Principle Amount (₹)	Maturity Amount (₹)
500	84	42,000	79,500
1,000	84	84,000	1,59,000
2,000	84	1,68,000	3,18,000
5,000	84	4,20,000	7,95,000
8,000	84	6,72,000	12,72,000

Supreme Vidya Savings Bond (10 Years)

Amount (₹)	Months	Principle Amount (₹)	Maturity Amount (₹)
500	120	60,000	98,500
1,000	120	1,20,000	2,01,750
2,000	120	2,40,000	4,13,000
5,000	120	6,00,000	10,56,250
8,000	120	9,60,000	16,14,000

Supreme Shubhalagna Savings Bond (15 Years)

Amount (₹)	Months	Principle Amount (₹)	Maturity Amount (₹)
500	180	90,000	2,25,000
1,000	180	1,80,000	4,50,000
2,000	180	3,60,000	9,00,000
5,000	180	9,00,000	22,50,000
8,000	180	14,40,000	36,00,000

* Terms and conditions apply

SUPREME SOUHARDA SAVINGS PLANS



Our institution offers various types of deposit facilities starting from savings account with good interest rates and also all Supreme Products Loan facilities to help you with your needs.



Supreme Souharda keeps your earnings valuable and life better.

For Soldiers / Senior Citizens / Disabled 1% extra interest facility.

Fixed Deposit (F.D)

30 Days - 90 Days - 7%

91 Days - 180 Days - 8.5%

181 Days - 360 Days - 9.5%

1 Year - 2 Years - 10.5%

2 Years - 3 Years - 11%

3 Years - 5 Years - 11.5%

Recurring Deposit (R.D)

1 Year - 9%

2 Years - 10%

3 Years - 11%



No - 687, Kotak Mahindra Bank building, 2nd floor, 3rd A-cross,
opp. Sheshadripuram college, MIG sector A, Yalahanka satellite town,
Bangalore - 560064

Mob: +91 83101 61483

E-Mail: supremesouharda2022@gmail.com

* Terms and conditions apply



Powered By:  **supreme**
Solar
Make Life Better!



SUPREME SOUHARDA CREDIT CO-OPERATIVE SOCIETY LTD

NO: R C S/R S R/SOUHARDA/REG/55/6061/2022-23

MIS FACILITY AVAILABLE

Supreme Souharda keeps your
earnings valuable and life better.



Fixed Deposit

F.D

11.5%

Get 1% extra interest for
Soldiers / Senior Citizens
& Disabled Persons.

**Recurring
Deposit**

11%

R.D

Daily Deposit

PIGMY

4%

✉ SUPREMESOUHARDA2022@GMAIL.COM

🌐 WWW.SUPREMESOUHARDA.COM

☎ 83101 61483



SUPREME MONTHLY INCOME SCHEME [MIS]

Sl.No	Principle Amount	Deposit Period	Monthly Interest	Quarterly Interest	Half Yearly Interest	Yearly Interest
1	50,000.00	1 Year	349.00	1,060.00	2,119.00	4,250.00
		2 Years	390.00	1,184.00	2,375.00	4,750.00
		3 Years	432.00	1,309.00	2,625.00	5,250.00
		5 Years	452.00	1,371.00	2,752.00	5,500.00
2	100,000.00	1 Year	698.00	2,120.00	4,238.00	8,500.00
		2 Years	780.00	2,368.00	4,750.00	9,500.00
		3 Years	864.00	2,618.00	5,250.00	10,500.00
		5 Years	904.00	2,742.00	5,504.00	11,000.00
3	200,000.00	1 Year	1,396.00	4,240.00	8,476.00	17,000.00
		2 Years	1,560.00	4,736.00	9,500.00	19,000.00
		3 Years	1,728.00	5,236.00	10,500.00	21,000.00
		5 Years	1,808.00	5,484.00	11,008.00	22,000.00
4	500,000.00	1 Year	3,490.00	10,600.00	21,190.00	42,500.00
		2 Years	3,900.00	11,840.00	23,750.00	47,500.00
		3 Years	4,320.00	13,090.00	26,250.00	52,500.00
		5 Years	4,520.00	13,710.00	27,520.00	55,000.00
5	1,000,000.00	1 Year	6,980.00	21,200.00	42,380.00	85,000.00
		2 Years	7,800.00	23,680.00	47,500.00	95,000.00
		3 Years	8,640.00	26,180.00	52,500.00	105,000.00
		5 Years	9,040.00	27,420.00	55,040.00	110,000.00
6	1,500,000.00	1 Year	10,470.00	31,800.00	63,570.00	127,500.00
		2 Years	11,700.00	35,520.00	71,250.00	142,500.00
		3 Years	12,960.00	39,270.00	78,750.00	157,500.00
		5 Years	13,560.00	41,130.00	82,560.00	165,000.00
7	2,000,000.00	1 Year	13,960.00	42,400.00	84,760.00	170,000.00
		2 Years	15,600.00	47,360.00	95,000.00	190,000.00
		3 Years	17,280.00	52,360.00	105,000.00	210,000.00
		5 Years	18,080.00	54,840.00	110,080.00	220,000.00

Powered by:  **supreme**
PRODUCTS
Make Life Better!er!

ASSOCIATE



SOLAR WATER HEATER



www.premiumsolars.com

TOP Home Appliance
SOLAR WATER HEATER SERIES

COMPANIES

Mfg by: ISO 9001:2008 & 14001:2015 Certified Company
SUN STORM
Powered by *supreme products*
SOLAR WATER HEATER



www.sunstorm.co.in

INTERNATIONAL

EGYPT



U.K



TANZANIA



DUBAI



MOROCCO



BANGLADESH



Supreme Products - A Global Presence

BRANCHES



**First Indian company to have Multiple
Global Branches !!**

GLIMPSE OF DISTRIBUTORS MEET - 2024

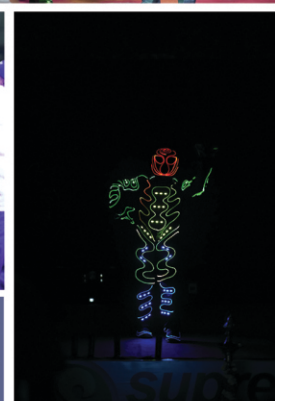



Some of our Franchise Showrooms in India



JOIN HANDS WITH US TO
Make Life Better!



Renewable Energy is  **Green,** Clean & Sustainable Energy





We

are one of the leading manufacturer of Solar water heater, Established in 2004. We have plans to establish our exceeding products to market; we are looking for Distributors all over India.

India's Largest SOLAR WATER HEATER Manufacturing company



BENGAURU



supreme
PRODUCTS
Make Life Better!

MADE IN INDIA



H.O.: Plot No 28C, Veerapura Village Kasaba Hobli, KIADB Doddaballapura Industrial Area,
Bangalore Rural - 561203

B.O ● Pune ● Delhi ● Indore ● Hyderabad ● Kolkata ● Nagpur ● Raipur ● Guwahati ● Cuttack

International



Kathmandu



Uganda



United Kingdom



Egypt



Nigeria



Kenya



United Arab Emirates



Morocco

We Welcome New Dealers / Distributors Across India
www.supremesolar.in