



**supreme**  
PRODUCTS  
Make Life Better!



World's best technology  
for serving hot water

## ETC Solar water heater

*Installation, Maintenance and User Manual*

*This manual contains all the necessary instructions regarding the installation, operation and maintenance of the product.*



The First Indian Solar Company with **KEY MARK** Certificate from Germany

# About Supreme Solar

Established in the year 2004 in Bangalore, Supreme Solar has grown from a modest customer base to a trusted brand in domestic water heater market across the country. It is listed as the top exporter of solar water heaters from India.

We introduce ourselves as a manufacturer of Solar Thermal Systems for domestic and Industrial applications. Our company is approved by Ministry of New and Renewable Energy (MNRE) - Government of India, New Delhi and we are one of their channel partners eligible for Capital Subsidy under JNNSM Scheme. Our company is ISO 9001 and ISO 14001 certified - giving added confidence to our customers on our passion for process and standardization.

We have our own Research Team, which is constantly researching on improvements in the systems to benefit our customers. We have more than 4500 Dealer-Distributor network across India.

SOLAR WATER HEATER SERIES



## BUSINESS OPPORTUNITIES

# We

are one of the leading manufacturer of Solar water heater, Established in 2004. We have plans to establish our exceeding products to market; we are looking for franchise all over India.

# India's

 largest SOLAR WATER HEATER Manufacturing company

# BANGALURU

Renewable Energy is  Green, Clean & Sustainable Energy



## DOMESTIC HOT WATER REQUIREMENTS

According to the statistics, the average consumption of a family varies from 35 to 50 litres per day per person. Adding the consumption of the washing machine and the dishwasher - if they are connected to the water heater - it is necessary to add about 20 litres of water more for each of them (for one wash) per day. So, for example, a family of four, with average consumption is 40 litres of hot water per person, needs 150L water heater. By adding the household appliances connected to the water heater, the needs then increase to at least 40 liters per day. In order to get the most out of the operation of the water heater, hot water should be used mainly during the day, so that the system can constantly produce hot water during the hours of sunshine, thus maintaining its maximum yield.



## SUPREME SOLAR SYSTEMS

Our system is an ecological proposal and an effective self-contained energy saving solution with high efficiency and ease of installation. They are made with excellent materials according to international specifications and have all the certifications and technical opinions that confirm their quality. They are aesthetic systems superior with simple installation and quick to implement in harmony with the architecture of the buildings and thus provide free hot water almost all year round. Even in areas with low sunlight, they provide water preheating, which significantly contributes to reducing conventional energy consumption. The use of solar systems in thermosiphon or forced circulation makes it possible to achieve an energy saving of 70-100%, since the operating time of the burner or electrical resistance decreases depending on the sunshine in the region concerned and the size of the system, with a simultaneous reduction in carbon dioxide emissions.

# OUR BEST SERVICES FOR CUSTOMERS



**supreme**  
PRODUCTS  
Make Life Better!

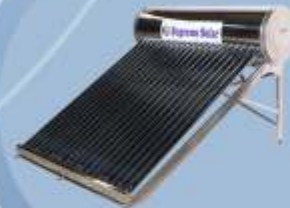

## ABOUT US

We are one of the leading manufacturer of Solar water heater, Established in 2004. We have plans to establish our exceeding products to market; we are looking for franchise all over India.

# BUY Now



Order Now  
[www.supremesolar.in](http://www.supremesolar.in)



**Each package includes all the necessary equipment as follows:**

1. The solar water storage tank
2. The Evacuated Tube Collectors (ETC)
3. Support Base, Attachments and Accessories

The accessories are packed in a cardboard box.

All individual parts of the support system with connection accessories and other accessories are packed in a separate carton.

The accessories for each system are listed in the table below:

| <b>ACCESSORIES IN THE BOX</b>   |                               |  |                          |
|---|-------------------------------|--|--------------------------|
| Depends On Water Heater models  |                               |  |                          |
|    | Heater Coil Dummy             |    | SS Pipe 3/4 inch 30cm    |
|  | Bush 1/4 inch                 |  | Float and ball           |
|  | 47 mm Dia Heater Dummy Washer |  | SS Pipe 3/4 inch 11cm    |
|  | Heater Coil Dummy cap         |  | M8X12mm Fasteners        |
|  | 58 Dia Anti Dust Black Washer |  | Heater coil              |
|  | 47 Dia PVC Cup                |  | 58 mm Dia Silicon Washer |

## Technical characteristics

### Solar Water Tank

**Coating of the inner tank:** Glasslined coating

**Internal tank corrosion protection:**

1. Glasslined coating completely protects and keeps the hot water clean and hygienic
2. Magnesium anode 3 cm in diameter and 50 cm long.

**Welding:** Plasma welded(CO<sub>2</sub>)

**Insulation:** High density expanded polyurethane (48Kgs/m)

**Inner Vessel Maximum Working / Test Pressure:**

1.5 bar - 5 bar (10 min)

**Maximum service temperature:** 75°C

**Siding :** GI With Powder Coated, Resistance to chemical attack and corrosion in a humid environment

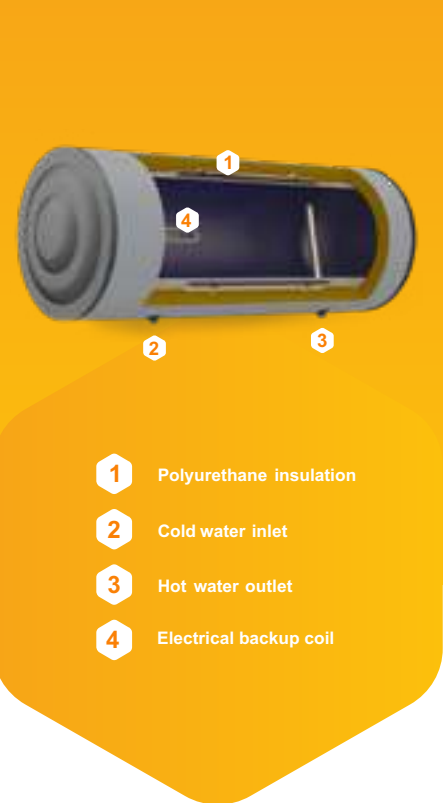

## Dimensions and capacities

### Solar Water Tank

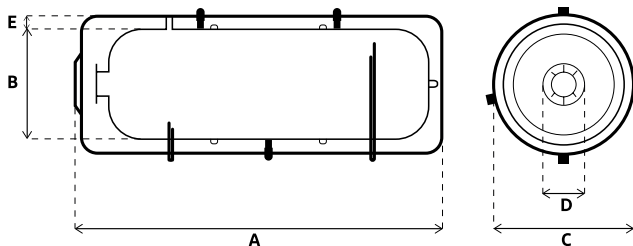

| SI.NO | PARTICULARS        | SPECIFICATION  |
|-------|--------------------|--|
| 1     | Inner Tank         | 1.2mm C.R.C.A sheet with co2 welding inside coated with prime guard coating /2.5mm for pressurized systems.              |
| 2     | Connecting Pipes   | SS 3/4" (nominal bore 20 mm) for hot water outlet and cold water inlet, 1 1/4" (nominal bore 33.6mm) for heating element |
| 3     | Insulation:        | 50 mm thick PUF  |
| 4     | Outer Cladding:    | pre-coated laminated sheet(color:Half white)/ Mirror finish  |
| 5     | End Caps:          | GI with PP coating.  |
| 6     | Support Structure: | Mild steel with powder coating.  |

## Technical characteristics of the Vacuum Tubes

Made of borosilicate glass 1.6 mm thick.

Coating of selective solar absorber made of Aluminum Nitride (**ALN**).

The component of the absorber consists of double coated glass tube.

Due to special geometry (shape) of the absorber, maximal absorption of solar energy is achieved.



| Vacuum Tube   |                                  |
|---|----------------------------------|
| Length of Vacuum tube<br>(Length of absorber)                                   | 1800 mm<br>(1720 mm)             |
| outer / Inner vacuum<br>diameter  | 58 / 47 mm                       |
| Glass thickness   | 1.6 mm                           |
| Material  | Borosilicate glass 3.3           |
| Selective coating   | SS - AlN/ Cu                     |
| Absorbance  | 0.90-0.95(AM1.5)                 |
| Emittance   | 0.04~0.06 (80°C±5°C)             |
| Vacuum Degree   | $P \leq 5.0 \times 10^{-3}$ (Pa) |
| Stagnation Temperature  | 260~300°C                        |
| Max efficiency<br>(for 20/15 vacuum tubes)<br>$T_m - T_a = 0K \ \& \ 1000W/m^2$ | 1383 W / 826 W                   |

### Evacuated Tube Collectors (ETC) based Solar Water Heaters

Evacuated Tube Collector is made of three layer borosilicate glass tubes evacuated for providing insulation. The outer wall of the inner tube is coated with selective absorbing material. This helps absorption of solar radiation and transfers the heat to the water which flows through the inner tube.

Solar water heating is now a mature technology. Wide spread utilization of solar water heaters can reduce a significant portion of the conventional energy being used for heating water in homes, factories and other commercial and institutional establishments. Internationally the market for solar water heaters has expanded significantly during the last decade.

## GENERAL INSTALLATION RULES

**WARNING:** The installation facility must comply with local and national regulations concerning water and electrical installations (plumbing, electricity, hygiene, town planning and others).

The solar water heater must be unpacked on the installation site to protect the device against knocks during transport. During installation, the collector windows must remain covered until the tank is filled with sanitary water in order to prevent the heat transfer. It is also necessary to eliminate the protective plastic caps by the connection of the water storage tank.

**Installation Position - Shade:** Before the installation of solar collectors, the correct choice of location (in agreement with the customer) and the control of the surface necessary for the installation of the device (taking into account its resistance static to support the weight of the system) are to be defined.

On sloping roofs, the storage tank should not be placed between two beams but plumb with one of them. The position chosen for the installation of the solar water heater should not be shaded by obstacles such as trees, buildings and the like during the whole year to reassure in order to obtain at least 4 hours of unobstructed exposure of the surface and harness maximum sunshine (noon).

| LATITUDE                            | DISTANCE BETWEEN OBSTACLE AND COLLECTOR (S) |
|-------------------------------------|---|
| 0 <sup>oh</sup> - 25 <sup>oh</sup>  | 1.0 x H                                     |
| 26 <sup>oh</sup> - 35 <sup>oh</sup> | 1.5 x H                                     |
| 36 <sup>oh</sup> - 45 <sup>oh</sup> | 2.0 x H                                     |
| 46 <sup>oh</sup> - 50 <sup>oh</sup> | 2.5 x H                                     |
| > 50 <sup>oh</sup>                  | 3.0 x H                                     |

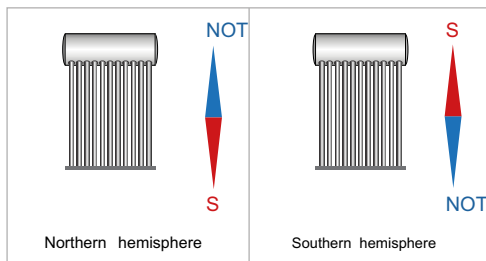
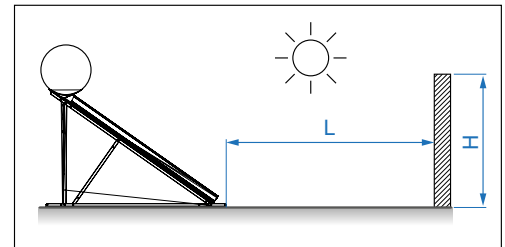

**Orientation-Optimal Angle:** A fundamental factor for optimum performance of the system is the choice of inclination and the time during which the maximum gain will be achieved. The solar system should be placed so that the collector surface is oriented to geographic south, for the northern hemisphere (north and longitude for the southern hemisphere), i.e., looking always towards the equator.

Deviation from the orientation means a decrease in system performance. If a deviation from the correct orientation cannot be avoided, then system performance should be corrected by increasing the collector area, after further study and evaluation of the specific conditions. Due to the angle of incidence of solar radiation which varies with time and system location, the angle of the collectors should be approximately equal to the latitude of the installation location. From this angle, the maximum annual energy gain is derived. Overhead tank should be minimum 6ft height for domestic systems and 8-10ft for industrial systems.

**Installation features:** In case there is no compatibility between the surface where the solar water heater will be installed (inclined or flat) and the standard equipment supplied with the system another type of equipment should be used. The responsibility for the chosen equipment will be on the installer and in no case on the company, it is up to the installer to propose and install the various necessary equipment, which must be previously agreed with the customer.

**Special weather conditions:** In areas affected by heavy rains and snowstorms, be careful to clear snow continuously. For this case and for regions where rain, strong winds, rains, cyclones, hurricanes, the system must be installed on the roof as stable as possible and must be tightened with additional metal bands. In areas where the above conditions exist and there is hail with a diameter of more than 20mm, solar water heater insurance is recommended. In any case, keeping the solar water heater on the support base system with more metal strips is recommended. Evacuated tube solar hot water systems contain water filled glass risers. The water is in a vacuum so it cannot freeze. Evacuated tube solar hot water system is rated to operate at  $-12^{\circ}\text{C}$  and so is suitable for the coldest parts of European countries.

**Piping:** The routing of the pipes and the wiring must be agreed between the installer and the customer, in order to ensure correct installation of the solar system in accordance with the local rules concerning water and electrical installations. The tubes connecting the water storage tank with the collector and the piping from/to the solar water heater must be insulated in such a way that they can withstand temperatures covering the range from -30°C to 120°C . UV protection should be used for insulation and piping should be finished properly insulated and covered against any rain and moisture.

## INSTALLATION POSITION

Installation is only permitted on roofs and flat surfaces of adequate load-bearing capacity. Before proceeding with the installation, make sure that the roof and / or the construction has sufficient bearing capacity in terms of bearing capacity, always according to the maximum loads expected at the point of installation. If the installation site is an area with a particularly high risk of wind and snow, the system as a whole must be checked statically by a qualified person, for example, a specialist engineer. In special cases, reinforcing or stronger constructions may be required.

| Collector  |  |                                    |
|--|--|------------------------------------|
| INSTALLATION MODE                                  | WIND LOAD<br>[km/ h] / [kN/ m <sup>2</sup> ] | SNOW LOAD<br>[kN/ m <sup>2</sup> ] |
| Inclined surface - Angle of inclination: 15° – 75° | 151 / 0.5                                    | 0.67                               |
| Flat surface - Angle of inclination: 35°           | 151 / 0.5                                    | 0.67                               |

The system can be installed only in regions with low wind and low snow loads than those mentioned above.

## SPACE REQUIREMENTS FOR ROOFTOP INSTALLATION

### TILED ROOF

When installing on the roof, pay particular attention to the following:

The minimum distances from the ends of the roof are:

- On the side: distance equal to the width of two tiles
- From the top of the roof: distance equal to three sets of tiles

The minimum distance limit of 0.8m must necessarily be respected, so that the sensors and mounting accessories are not exposed to winds whose power increases at the perimeter of the edges of the roof.

### SPACE REQUIREMENTS FOR LOOSE FIXING

#### FLAT ROOF

The system should be installed at least 1.5m from the edge of the roof, in order to:

Allow access around the system for maintenance purposes. The collector and the fixing system must not be exposed to strong winds which are developed at the ends of the roof. Allow snow removal.

## LABELING

Solar water heaters are identified using sticker, which is placed on the solar tank. The characteristics of the system are shown on this sticker. This information is important for reasons of product traceability.

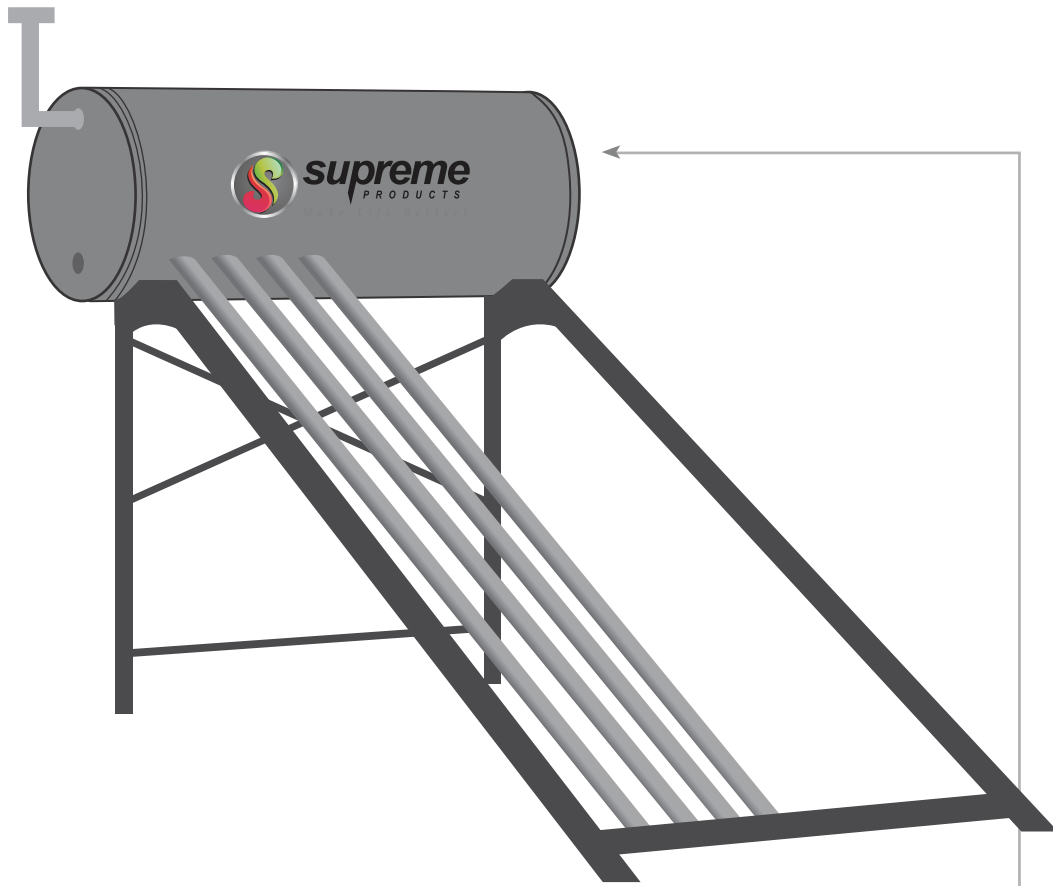

|   |  |   |  |
|---|--|---|--|
|  <b>supreme</b><br>PRODUCTS<br><i>Make Life Better!</i>  |  | <b>Brand : SUPREME SOLAR</b>                              |  |
| ISO 9001:2015 & 14001 : 2015<br>CERTIFIED COMPANY   |  | <b>Model :- xxx LPD ETC GL</b>                            |  |
| <b>SUPREME SOLAR PROJECTS PVT LTD.</b>  |  | <b>Nominal capacity of the storage vessel :- xxx Ltrs</b> |  |
| <ul style="list-style-type: none"> <li>Plot No 28/C Sy. no. 92,93,94 &amp; 95,<br/>             Veerapura Village, Kasaba Hobli,<br/>             KIADB, Doddaballapura Industrial Area,<br/>             Bengaluru-561203. India<br/>             Phone No : +91 78925 28719<br/>             www.supremesolar.in</li> </ul> |  | <b>Maximum operating pressure :- xxx bar</b>              |  |
|   |  | <b>Gross area of the collector :- xxx m2</b>              |  |
|   |  | <b>Aperture area of the collector :- xxx m2</b>           |  |
|   |  | <b>Collector heat transfer fluid :- Water</b>             |  |
|   |  | <b>Vol. of heat transfer fluid :- xxx Ltrs</b>            |  |
| <b>Month and Year of Manufacture :</b>  |  | <input type="text"/>                                      |  |
| <b>Sl. No. :</b>  |  | <input type="text"/>                                      |  |

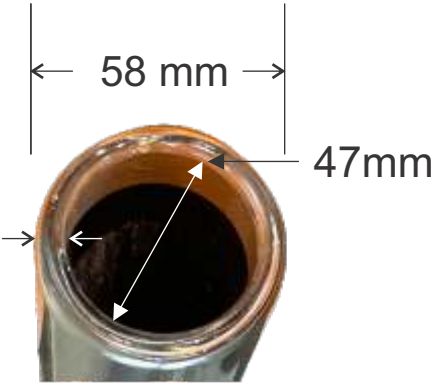

**BOOK  
NOW**

[WWW.SUPREMESOLAR.IN](http://WWW.SUPREMESOLAR.IN)



## GENERAL PREVENTION MEASURES

Comply with the applicable accident prevention instructions and safety rules, during installation of solar systems and piping.

Keep the work area clean and free of objects that prevent work from being carried out.

Keep children, pets and unauthorized persons away from tools and installation site. This applies particularly in the case of buildings undergoing residential renovation.

During maintenance, repair, conversion and in the event of changes to the installation, remove electrical devices and secure the installations and electrical tools against unintentional activation. For collector cleaning should not be carried out at day time (sunny hours).

Use only components intended for this system. The use of other accessories or improper tools can cause accidents.

### Conditions relating to personnel.

The installation of our Solar Thermal systems is carried out only by specialized companies, authorized and by qualified personnel should ITI or diploma holder.

Work on electrical installations or pipelines is only authorized for specialists and qualified technicians should be ITI or diploma holder (electrical).

### Work uniforms

Wear protective goggles, suitable work uniform, protective shoes, protective helmet and a special net for long hair.

Do not wear loose clothing or jewelry because they can get caught in moving parts.

Wear a hard hat during installation work that is overhead or at head level.

### Installation of the water storage tank

For transport, setting up and installation, use lifting devices corresponding to the dimensions and the weight of the tank.

Protect the enamel coating of the tank against knocks during transport and installation.

Due to the weight of the storage tank, there is a risk of accidents. Please ensure that the load bearing capacity of the ground at the installation site is sufficient when the storage tank is full.

## PROTECTION AGAINST LIGHTNING

As per European standard EN 62305-3 particularly to assist in determining the protection measures required to establish protection measures to counter Lightning Electromagnetic Impulse (LEMP) within a structure with proper earthing. The metal construction complies with the general requirements of the standard and the specific lightning protection requirements of the standard which takes into account environmental conditions as well as altitude.

## Product Dimensions

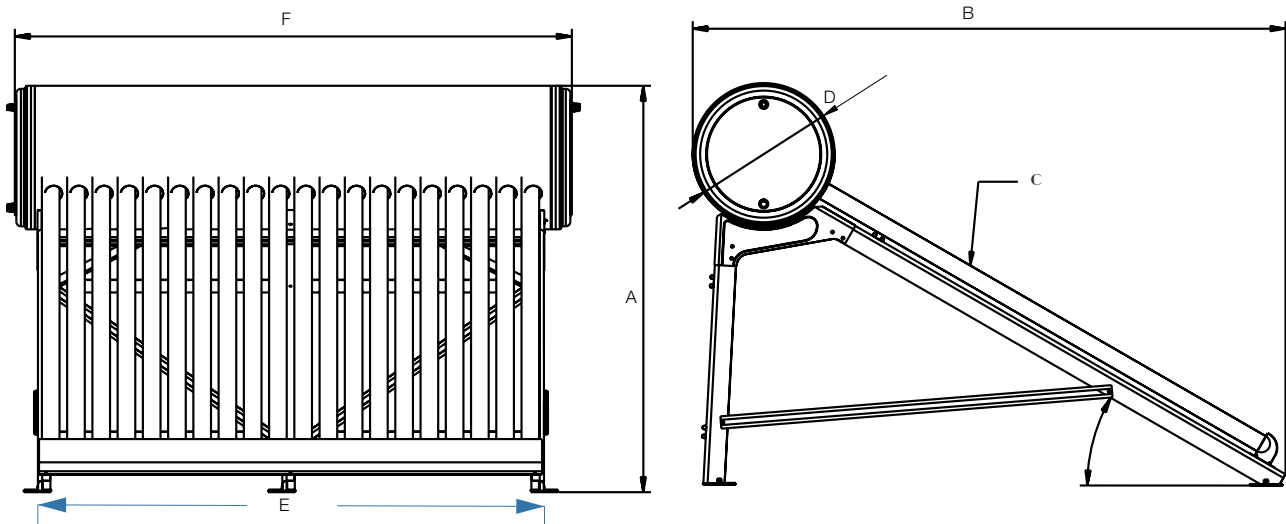

| Model            | A       | B       | C       | D      | E       | F       |
|------------------|---------|---------|---------|--------|---------|---------|
| Supreme 100 L PD | 1342 mm | 1976 mm | 1800 mm | 472 mm | 778 mm  | 1053 mm |
| Supreme 150 L PD | 1342 mm | 1976 mm | 1800 mm | 472 mm | 1193 mm | 1468 mm |
| Supreme 200 L PD | 1342 mm | 1976 mm | 1800 mm | 472 mm | 1608 mm | 1883 mm |
| Supreme 300 L PD | 1342 mm | 1976 mm | 1800 mm | 472 mm | 2023 mm | 2713 mm |
| Supreme 500 L PD | 1342 mm | 1976 mm | 2100 mm | 550 mm | 3040 mm | 3350 mm |

## THERMOSIPHON PRINCIPLE

This type of solar water heater uses the sun to heat the water in the vacuum tubes. The solar collectors absorb solar radiation, convert the sunlight to heat and transfer it to the water.

The heated water naturally rises through the solar collector into the tank where the water at the base of the tank is forced out and descends to the bottom of the collector. This is called thermosiphon circulation.

The circulation works only under sunlight whereas active solar water heating systems rely on electric pumps, valves, and controllers to circulate the water through the vacuum tube collector, a thermosiphon system relies on gravity and the tendency for water to naturally circulate as it is heated. Since complex mechanical liquid pumps are not necessary, these types of systems are reliable and cost-effective solutions for hot water generation.

Thermosiphon systems are mainly used in regions with high solar radiation.

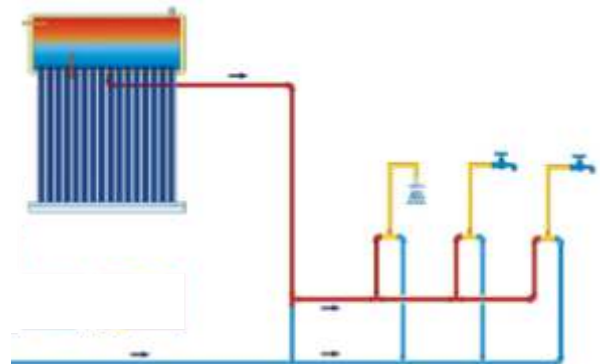
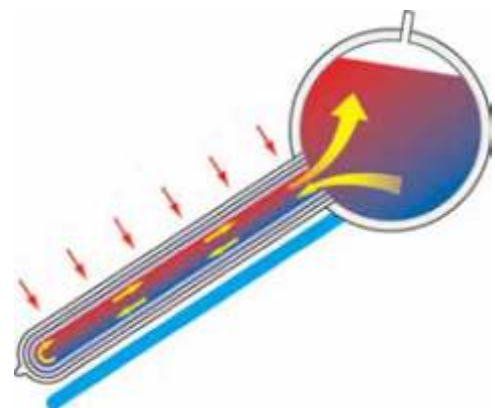

# TECHNICAL SPECIFICATION

| SI.NO | PARTICULARS                | SPECIFICATION  |
|-------|----------------------------|--|
| 1     | Vacuum Tube outer diameter | 47/58 mm   |
| 2     | Vacuum Tube inner diameter | 37/47 mm   |
| 3     | Tube length                | 1800 mm / 2100 mm  |
| 4     | Outer Tank Diameter        | 480 mm / 550 mm  |
| 5     | Inner Tank Diameter        | 380 mm / 450 mm  |
| 6     | Tank Volume                | 100 LPD, 125 LPD, 150 LPD, 200 LPD, 250 LPD, 300 LPD, 500 LPD  |
| 7     | Temperature                | 65 degree C to 85 degree C   |
| 8     | Tank Insulation            | PUF 50mm (polyurethane foaming)  |
| 9     | Stand frame                | Galvanized Power coated  |
| 10    | Inner tank material        | High-Grade Steel / Ceramic / Glasslined - enamel coated  |
| 11    | Outer Tank Material        | Galvanized Power coated  |
| 12    | Method of Welding          | Seam less and Non Welding Technology / MIG   |
| 13    | Type of Fasteners          | Galvanized   |
| 14    | Type of Grommets           | Silicon Rubbers  |
| 15    | Type of Circulation        | Thermosyphon   |
| 16    | Electrical Back Up         | 2 KW/ 3 KW   |
| 17    | Type of inlet feeding      | Using gravity feeding tank of non-pressure.low mixing of hot and cold water,and long life of inner tank.(optional) |

| CAPACITY | 47 mm | 58 mm |
|----------|-------|-------|
| 100 LPD  | 12    | 10    |
| 125 LPD  | 15    | –     |
| 150 LPD  | 18    | 15    |
| 200 LPD  | 24    | 20    |
| 250 LPD  | 28    | 24    |
| 300 LPD  | 35    | 30    |
| 500 LPD  | 55    | 50    |

## ELECTRICAL CONNECTION

### DESCRIPTION OF ELECTRICAL COMPONENTS (heating element- thermostat- accessories)

#### ELECTRICAL DIAGRAM – GENERAL RULES

The emergency heating system should only be used for emergency heating. The electrical installation of the solar water heater must be carried out only by qualified electricians, in accordance with the national regulations in force, the rules and the conditions which apply to the buildings where the installation is carried out.

The heating element (resistance) must not be switched on when there is no water in the storage tank. In such a case, the heating element (resistance) warranty does not apply.



D.1



D.2



D.3



D.4

**NOTE:** The heating element (resistance) depends on the local regulations of the country of destination.

1. Remove the screws from the protective cover that covers the electrical components (D.1).
2. A 3x4mm<sup>2</sup> electrical cable (for a 2 - 3kW heating element) is required to connect the heating element to the electrical network (D.2).
3. Pass the end of the cable through the cable gland to the electrical components.
4. Connect the black wire (phase) to connector L and the blue wire (neutral) to the connector on the thermostat N. Connect the yellow wire (earth) to the small M4 screw on the heating element (resistor) marked with the symbol of earth (D.3).
5. The thermostat has been wired to the heating element at the factory. Set the thermostat to 60°C.

**Warning!** The thermostat must be well adapted to the heating element (D.1).

6. Close the electrical component cover (D.4).
7. Switch off the central circuit breaker of the network.
8. Connect the other end of the cable to the electrical panel using a two-pole circuit breaker with the disconnection at a minimum distance between the contacts of at least 3mm. The rating of the circuit breaker must be suitable for the heating element used.

**Warning!** A safety relay against electric shock is absolutely necessary.

**NOTE:** Hot water load per day (40°C) which can be met by the system without any solar energy contribution (only through 24h operation of 2kW heating element) according to EN 12976 5.10 - 2:2000 is 1000lt maximum.

## THE WATER STORAGE TANK DOES NOT SUPPLY HOT WATER WHEN THE ELECTRIC HEATER IS USED.

The following tasks should only be performed by a qualified electrician.

1. Turn off the power supply and open the electrical component cover.
2. Check the cable connection between the thermostat and the heating element.
3. Check the temperature at which the thermostat is set, so that it is not less than that it is necessary for consumption.
4. Check the heating element.
5. Check the central electrical connection.
6. Turn on the electrical current and measure the voltage across the heating element.
7. Check the thermoelectric cut-out of the thermostat, which must be pressed. If not, turn the thermostat regulator to the thermoelectric fuse button appears. Press the one. Once it has been reset, the thermostat can work again.

## MAINTENANCE SERVICE

Your solar water heater should be serviced every two years by an authorized representative or company technician. These periodic checks are necessary for the guarantee of the solar water heater. The inspection covers the entire system and more specifically:

1. Flange
2. Safety valve
3. The heating element - thermostat
4. Fittings
5. Piping
6. Insulation - Joints
7. Transparent cover (sunglass)
8. The support system
9. Replacing the anode and checking the closed circuit liquid.

*It is recommended that the water storage tank be inspected and cleaned every two years.*



### Especially for the replacement of the anode bar proceed as follows:

1. Switch off the power supply.
2. Empty the water from the water storage tank.
3. Remove the electrical protection cover.
4. Disconnect the three electrical cables.
5. Remove the electric heating element by removing the M8 screws.
6. Remove the magnesium anode from the heater element flange.
7. Screw in the new anode.
8. Replace the heating element with the rubber gasket.
9. Turn on the water supply and a hot water tap until the water storage tank is full.
10. Check for water leaks.
11. Reconnect the electrical components to their designated outlets.
12. Check that the thermostat is firmly attached to the heating element.
13. Replace the electrical component cover.
14. Reconnect the power supply.

**For solar tanks with a coil, a periodic check by a qualified technician is recommended.**

# VAJRA MODEL

330LPD Heat Pipe and Heat Exchanger **pressurised** model



## VAJRA MODEL

HEAT PIPE HEAT EXCHANGER

## PRESSURISED

### Technical Specifications

|                      |  |
|----------------------|--|
| Type Of Collector    | : ETC  |
| Specifications       | : 58 - 2100 mm                                       |
| Frame Angle          | : 27 Degrees   |
| Inner Tank Materials | : Enamel Steel Of 2.5 mm<br>With Glass Lined Coating |
| Inner Dish           | : 2.5 mm   |
| Outer Dish           | : Aluminum With Powder Coated.                       |
| Insulation           | : 50 mm High Quality PUF Materials.                  |
| Outer Tank           | : Powder Coated / Stainless Steel.                   |

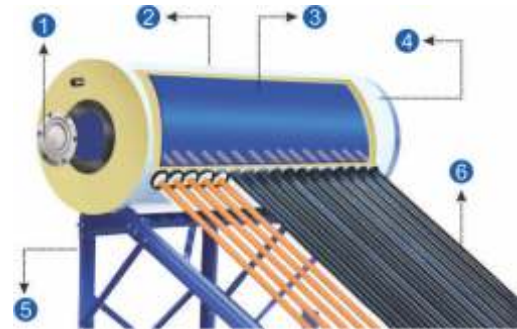

- |   |  |
|---|--|
| <p>❶ Doors Provided for cleaning purpose</p> <p>❷ High-Pressure   High-Density PUF Insulation<br/>Keeps water warm for longer</p> <p>❸ Special Profile Rolled Section Stand<br/>Provides stability and strength to the system</p> | <p>❹ Glass Lined Coating to avoid rust</p> <p>❺ Capsule Dish-End-Shaped Tank<br/>Withstands greater pressure</p> <p>❻ 3T Gold Standard Tubes<br/>Gives you maximum hot water</p> |
|---|--|



## INSTALLATION DIAGRAM ETC 304 MODEL

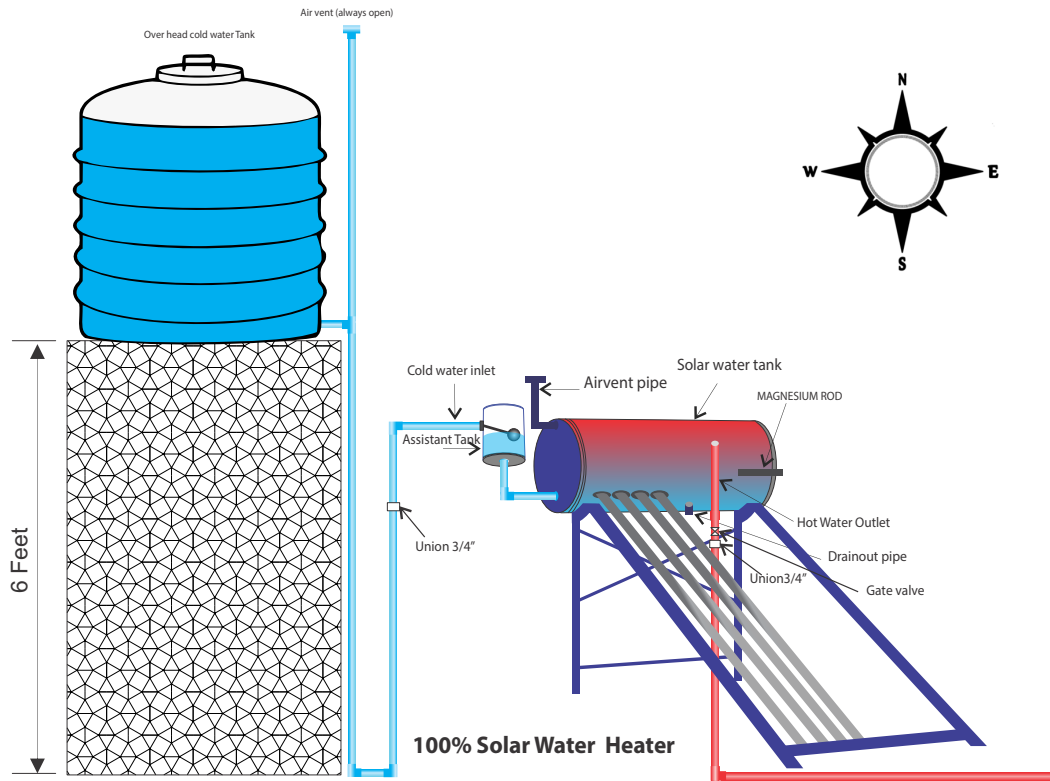

## MULTIPLE INSTALLATION DIAGRAM WITH PARALLEL CONNECTION

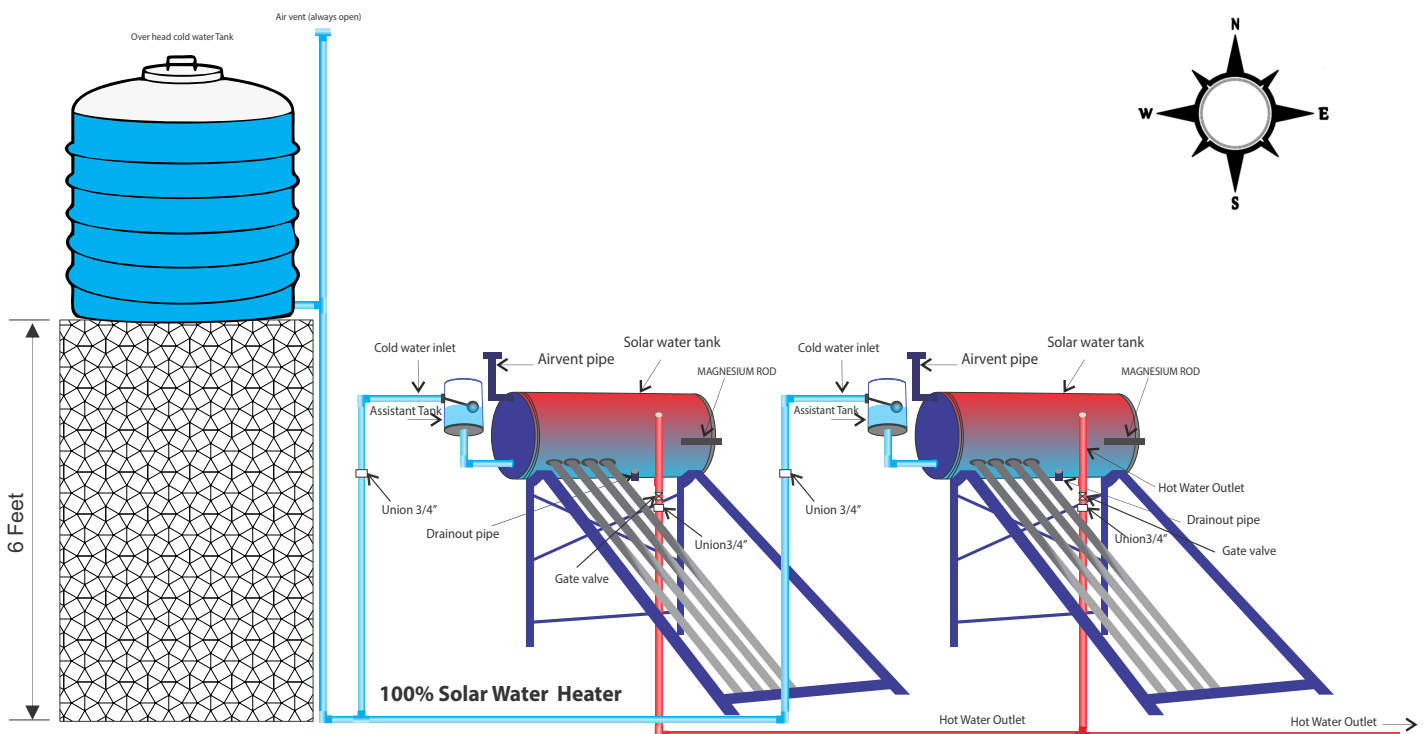

## INSTALLATION DIAGRAM ETC G-LINE MODEL

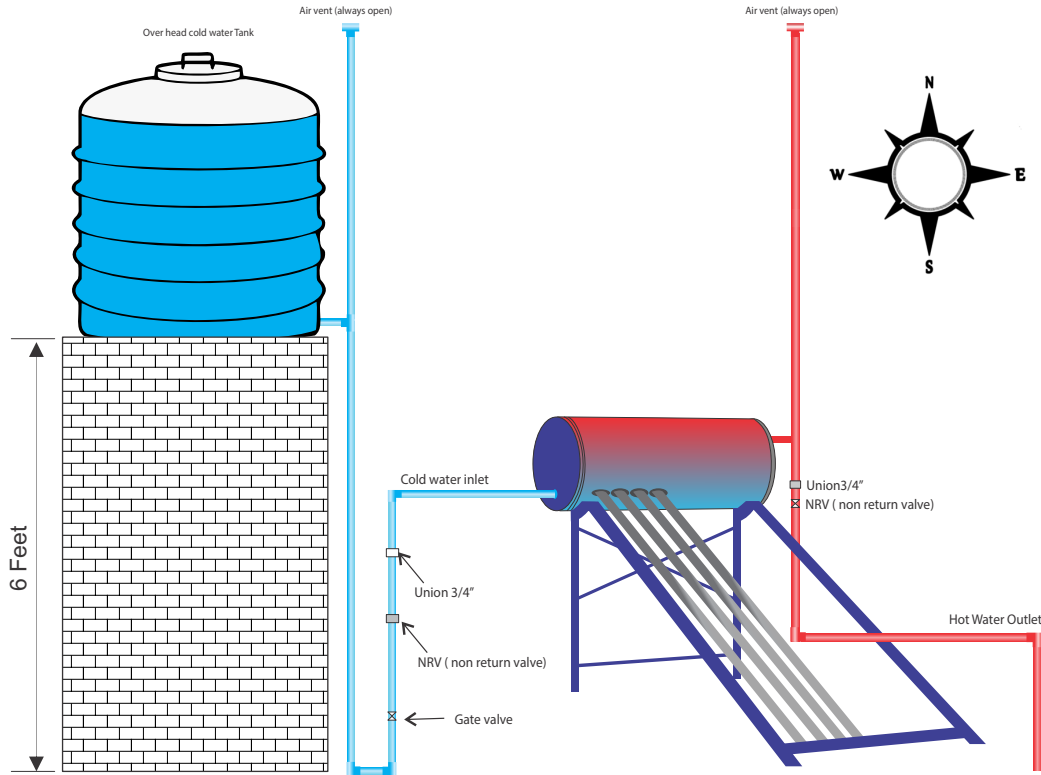

## INSTALLATION DIAGRAM VAJRA PRESSURISED MODEL

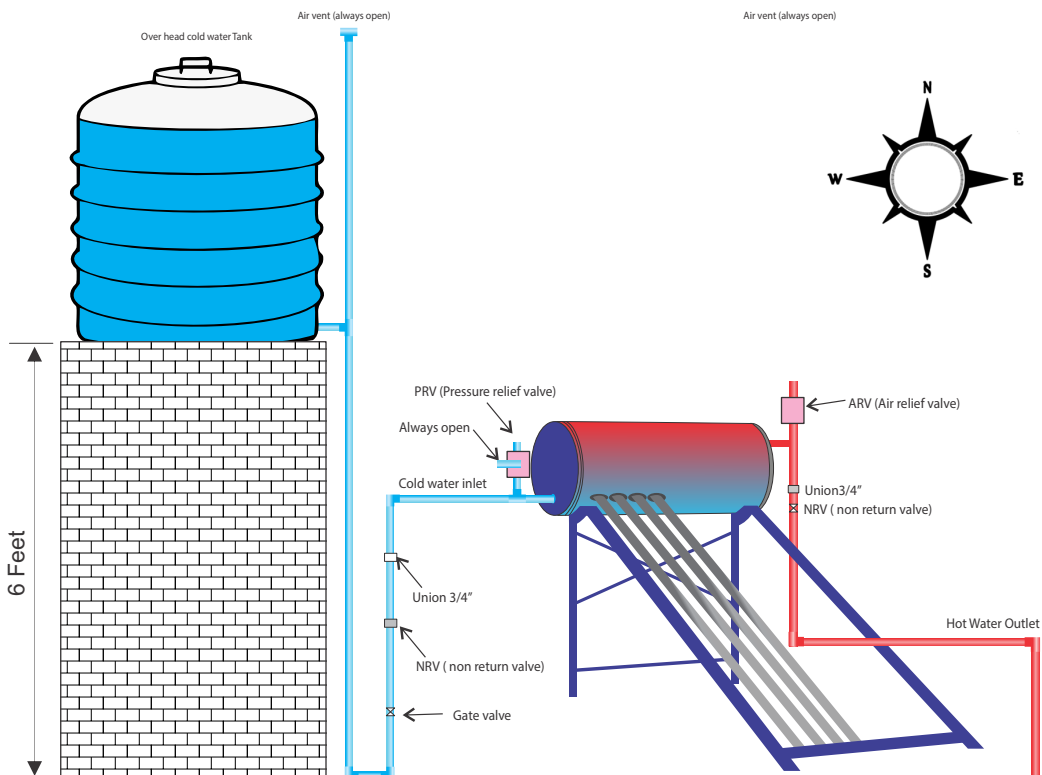

# TOP Home Appliance SOLAR WATER HEATER SERIES

## SUPREME ETC SS MODEL

SOLAR WATER HEATER(SS)



Three coated  
Vacuum tube

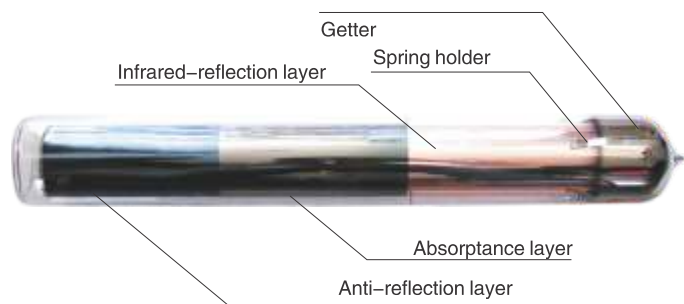
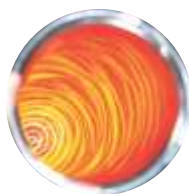

# TOP Home Appliance SOLAR WATER HEATER SERIES



Switch on the sun

Free hot water for life

**Govt. Approved  
Company**

## SUPREME ETC MODEL

SOLAR WATER HEATER(PC)

- **Supreme Solar SS ETC 304L** Grade model suitable for water hardness up to **300 PPM**
- **Supreme Solar GL ETC** model Suitable for water hardness up to **4000 PPM**
- **Supreme Solar Ceramic ETC** model suitable for water hardness upto **1000 PPM**
- **Please test water Hardness before Installing solar Water Heater**

## Technical Specifications

|                      |                                   |
|----------------------|-----------------------------------|
| Type of collector    | : ETC                             |
| Specifications       | : 58-1800mm                       |
| Frame angle          | : 27 Degrees                      |
| Inner tank materials | : High grade materials            |
| Insulation           | : High quality PUF materials      |
| Tank Volume          | : 100Ltrs - 500Ltrs               |
| Outer tank           | : Powder coated / Stainless steel |

**TOP** Home Appliance

## SOLAR WATER HEATER SERIES



**SUPREME ETC GLASS-LINED MODEL**

**SOLAR WATER HEATER(SS)**

### Technical Specifications

|                      |   |
|----------------------|---|
| Type of collector    | : ETC   |
| Specifications       | : 58 - 2100   |
| Frame angle          | : 27 Degrees  |
| Inner tank materials | : Enamel steel of 2mm & 2.5mm<br>with glass lined coating |
| Outer tank           | : Stainless steel   |
| Inner dish           | : 2.5mm   |
| Insulation           | : 50mm high quality<br>PUF materials                      |

**TOP** Home Appliance

## SOLAR WATER HEATER SERIES

**SUPREME ETC GLASS-LINED MODEL**

SOLAR WATER HEATER(PC)



### Technical Specifications

|                      |   |
|----------------------|---|
| Type of collector    | : ETC   |
| Specifications       | : 58 - 2100   |
| Frame angle          | : 27 Degrees  |
| Inner tank materials | : Enamel steel of 2mm & 2.5mm<br>with glass lined coating |
| Outer tank           | : Powder coated & Stainless steel                         |
| Inner dish           | : 2.5mm   |
| Outer dish           | : Aluminum with<br>Powder coated                          |
| Insulation           | : 50mm high quality<br>PUF materials                      |



Solar Water Heaters 150L Sleeper Model



Solar Water Heaters 200L Sleeper Model



Solar Water Heater 200L Full SS Model

Solar Water Heaters 200L Full SS Model



**More precisely:** To connect the solar system heat exchangers to the central water system storage tank, follow the steps below:

1. Connect the connectors to inlet and to outlet of the exchanger.
2. Place a shut-off valve of the appropriate diameter.
3. Place the automatic air vents both on the water supply and on the return from the tank to the boiler.
4. Insulate all connecting pipes with at least 9mm insulating material.
5. Fill the system with water and check for leaks.

## POSSIBLE PROBLEMS-SOLUTIONS

### **THE SOLAR WATER STORAGE TANK DOES NOT DELIVER A SATISFACTORY AMOUNT OF HOT WATER BY SOLAR ENERGY**

1. Take weather conditions into consideration.
2. Avoid high hot water consumption over night.
3. Check if your hot water needs are not higher than the capacity of the system.
4. Ensure that your solar water heater is not shaded by any kind of obstacles.
5. Check that the system is level.
6. Carefully check all connections for tightness and tighten or replace all connections that are not over tight.
7. Check the building's plumbing and faucets for the possibility of a slow leak.
8. Ensure the hot water supply is not mixing with a cold water supply.
9. Ensure that the connecting pipes are not bent.
10. Ensure there is no trapped air in the water storage tank.
11. Collector must be covered from overheating and freezing during un use of solar water heater

### **recommendations on measures to reduce risk of Legionella proliferation**

1. Regularly flush the system (especially outlets that are used infrequently)
2. Remove any dead legs/dead ends in the pipe system
3. Conduct a quarterly shower head/hose clean
4. Annually inspect cold-water storage tanks and clean when required
5. Drain hot water units to check for any debris or corrosion

*If, after all the above checks, you are still not satisfied with the performance of your solar system, then please contact your local representative or the company's technical department.*

## ATTENTION!

- Any intervention - work on the solar water heater must be carried out only by specialized technicians and where the electrical components are concerned, only by qualified and authorized electricians.
- All solar water heater maintenance data must be mentioned on the cards on the warranty document (duration of warranty).
- In areas where extreme weather conditions are common (hailstorms, storms, tornadoes, etc.), it is recommended that the device is insured.

## PRE-INSTALLATION TASKS

Before using the system, make a final check. Open all valves and check for leaks. Repeat the inspection after thirty minutes. Check that the system is filled with water according to the company's instructions. In case of any failure condition a specialized technician should be called in. After its installation, the solar water heater requires about two days to reach a performance of the higher level. For this reason, the use of hot water for the first two days after installation is not recommended, even if there is strong sunlight. Periodic maintenance ensures the longevity and superior performance of the system.

- On-site monitoring of the device is recommended twice a year and have the collector tubes checked for damage (breakage), leaks in the connection pipes to the water and supply network, inspection of tube insulation and proper seating of the collectors.
- If the collector glass breaks, it must be replaced immediately.
- In the event of deterioration of attachments, screws, dowels, pipes etc., they must be replaced at the expense of the customer.
- In cases where there is no hot water withdrawal for a long time (summer vacation, for example), covering the collector surface is advisable with an opaque cover in order to avoid overheating, which could trigger the thermoelectric cut-out of the thermostat and break the electrical circuit.
- During the development of high pressures at the storage tank, it is possible to activate the safety valve and let water escape. This is normal operation and its purpose is to protect the solar water heater from pressure. If the water circuit pressure exceeds 4 atm., the adaptation of a pressure reducer, pressure- expansion tank required.
- Do not switch on the electrical resistance in the following cases:
  - A) In the event of a water cut in the water network.
  - B) In the event of frost, when the connection pipes are frozen and the water flow from the solar water heater at the taps is not possible.

**Warning!** The use of a tap with thermostatic regulation up to 38°C on the domestic hot water supply is mandatory to avoid burns which can be caused by water stored at high temperature in the solar water heater .

We remain at your disposal for any further information. We can assure you that you have made the best choice. Thank you for choosing our products, we appreciate your trust.

# LIST OF CONTROLS

## INSTRUCTIONS FOR THE INSTALLER

After the completion of the installation, the installer with the help of the checklist below, must check all the points that are noted and mark in the corresponding column with a ✓.

| LISTING  | CHECKED |
|--|---------|
| <b>COLLECTORS AND PIPING (EXTERIOR)</b>  |         |
| Is the installation and fixing of the support base in accordance with the instructions and local regulations in force? |         |
| Is the collector place clean?  |         |
| Is there moisture inside the collector?  |         |
| Are the plumbing connections correct?  |         |
| Is the thermal insulation resistant to ultraviolet (UV) rays?  |         |
| Are the pipes well insulated?  |         |
| Is the installation on roofs in accordance with the local regulations in force?  |         |
| <b>HYDRAULIC CONNECTIONS</b>   |         |
| Are there leaks in the closed circuit connections or in the heat exchanger of the tubes?                               |         |
| Are the safety valves properly installed?  |         |
| Is there a thermostatic mixer?   |         |
| <b>ELECTRICAL CONNECTIONS</b>  |         |
| Is the electrical resistance connected correctly? (if it exists)   |         |
| Was the electrical connection carried out in accordance with the local regulations in force? (insulation, earth, etc.) |         |
| <b>IN GENERAL</b>  |         |
| Is the guarantee duly filed and returned to the customer?  |         |
| Have instructions for use been provided to the customer?   |         |
| Is the appropriate choice of model made according to the customer's needs?   |         |
| Was the customer informed of other options that exist for the production of domestic hot water?                        |         |

### Installer sheet

Full name .....

Address .....

Contact Number.....

### Distributor sheet

Full name .....

Address .....

Contact Number.....



**supreme**  
PRODUCTS

*Make Life Better!*

**SUPREME SOLAR PROJECTS PVT. LTD**

**H.O : Plot no 28C, KIADB Doddaballapura industrial area, Bangalore India - 561203.**

**Branches :** • Hyderabad • Pune • Delhi • Indore • Kolkata • Raipur • Ahmedabad  
• Guwahati • Cuttack

**International :** • Katmandu • Dhaka • Kenya • Uganda • Egypt • Morocco • UK

**For Dealer / Distributors / Franchise Enquiries Visit [www.supremesolar.in](http://www.supremesolar.in)**